



## Estimation of triethylene glycol (TEG) purity in natural gas dehydration units using fuzzy neural network



Mohammad M. Ghiasi<sup>a,\*\*</sup>, Alireza Bahadori<sup>b,\*</sup>, Sohrab Zendehboudi<sup>c</sup>

<sup>a</sup>National Iranian Gas Company (NIGC), South Pars Gas Complex (SPGC), Asaluyeh, Iran

<sup>b</sup>Southern Cross University, School of Environment, Science and Engineering, Lismore, NSW, Australia

<sup>c</sup>Department of Chemical Engineering, University of Waterloo, Waterloo, Ontario, Canada

### ARTICLE INFO

#### Article history:

Received 2 October 2013

Received in revised form

26 December 2013

Accepted 30 December 2013

Available online

#### Keywords:

TEG

Natural gas dehydration

Glycol reconcentrator

ANN

Prediction

### ABSTRACT

Natural gas usually contains a large amount of water and is fully saturated during production operations. In natural gas dehydration units' water vapor is removed from natural gas streams to meet sales specifications or other downstream gas processing requirements. Many methods and principles have been developed in the natural gas dehydration process for gaining high level of triethylene glycol (TEG) purity. Among them, reducing the pressure in the reboiler at a constant temperature results in higher glycol purity. The main objective of this communication is the development of an intelligent model based on the well-proven standard feed-forward back-propagation neural network for accurate prediction of TEG purity based on operating conditions of reboiler. Capability of the presented neural-based model in estimating the TEG purity is evaluated by employing several statistical parameters. It was found that the proposed smart technique reproduces the reported data in the literature with average absolute deviation percent being around 0.30%.

© 2014 Elsevier B.V. All rights reserved.

### 1. Introduction

Generally, large amount of water is accompanied by natural gas (NG) in the reservoir. Because of this, the produced NG is completely saturated or at the water dew point. With the aim of meeting sales specifications or other downstream gas processes like gas liquid recovery, gas dehydration operation is employed in NG industry to remove the water vapor (Bahadori, 2009a; Bahadori, 2009b; Bahadori et al., 2008). From economic and safety points of view, the water moisture content of NG must be maintained below a certain threshold (Bahadori, 2007; Bahadori and Vuthaluru, 2009a,b; Gharagheizi et al., 2013; Ghiasi, 2012; Ghiasi and Mohammadi, 2013; Masoudi et al., 2005; Mohammadi et al., 2005).

In cases where dew point depressions should be of the order of 15° to 49 °C, glycols are commonly used (Lubenau and Mothes,

2009). Amongst different glycols such as diethylene glycol (DEG), triethylene glycol (TEG), and tetraethylene glycol (TREG), that are used as liquid desiccants, the most common choice for NG dehydration is TEG (Piemonte et al., 2012). Operation and maintain of liquid desiccant dehydration equipment is simple (Gironi et al., 2010; Nivargi et al., 2005). This type of dehydration could be easily automated for unattended operation; glycol dehydration at a remote production well is such an example (Bahadori, 2009b; GPSA, 2004).

Fig. 1 shows the gas stripping section in NG dehydration unit. It is well-known that pressure reduction in the reboiler (reconcentrator) at a constant temperature contributes to higher glycol purity. Operating range of most reconcentrators is between 1.7 and 5.2 kPa of pressure (Stewart and Arnold, 2011; Wichert and Wichert, 2004). On standard atmospheric reconcentrators, pressures more than 7 kPa could lead to glycol loss from the still column and reduction of both lean glycol concentration and dehydration efficiency (Bahadori et al., 2014). Furthermore, pressures more than 7 kPa are commonly associated with excess water in the glycol. Consequently, a vapor velocity exiting the still great enough to sweep glycol out will be created (Stewart and Arnold, 2011). On the other hand, pressures less than atmospheric are responsible for increase in the concentration of lean glycol. This is a consequence of decrease in boiling temperature of rich glycol/water mixture (Stewart and Arnold, 2011).

**Abbreviations:** ANN, Artificial neural network; BPNN, Back-propagation neural network; DEG, Diethylene glycol; FFNN, Feed-forward neural network; FLN, Functional link networks; LM, Levenberg–Marquardt; MLP, Multilayer perceptron; MSE, Mean squared error; NG, Natural gas; RBFN, Radial basis function network; TEG, Triethylene glycol; TREG, Tetraethylene glycol.

\* Corresponding author. Tel.: +61 (0) 422789572; fax: +61 266269857.

\*\* Corresponding author.

E-mail addresses: [mm.ghiasi@gmail.com](mailto:mm.ghiasi@gmail.com) (M.M. Ghiasi), [Alireza.bahadori@scu.edu.au](mailto:Alireza.bahadori@scu.edu.au) (A. Bahadori).

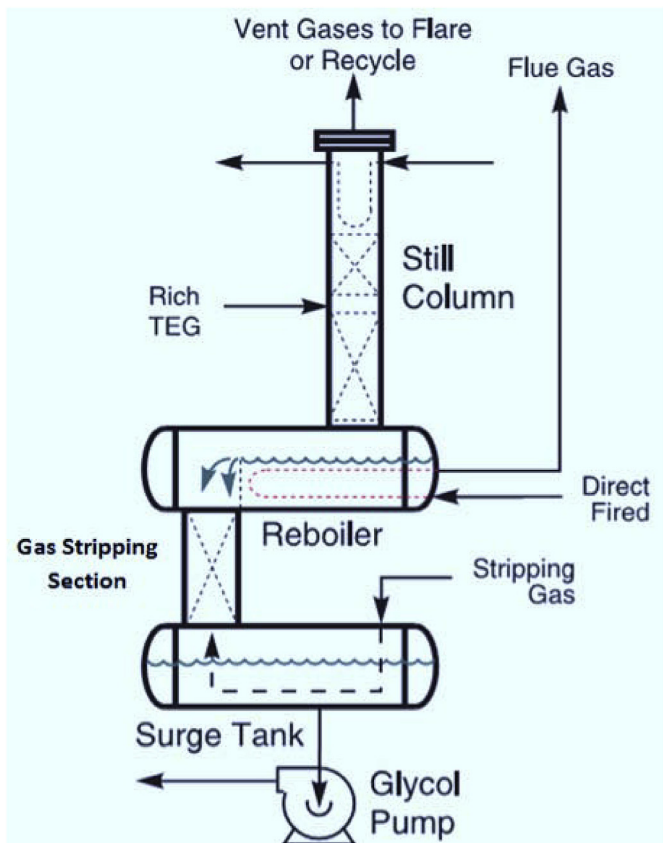

Fig. 1. Schema of gas stripping section in NG dehydration unit.

As a result of aforementioned issues, it is crucial to calculate TEG purity as a function of reconcentrator pressure and temperature. The main objective of the presented study is evolving a neural-based model for accurate prediction of TEG purity on the foundation of multilayer perceptron (MLP) artificial neural network (ANN) as a well-proven algorithm of machine learning approach. To the best of author's knowledge, there is no published work on the subject of TEG purity modeling versus reboiler temperature at various levels of pressure in gas dehydration systems by means of MLP neural networks. Overview of ANNs, computational procedure to develop a proper model, and results of the presented model constitute the rest of the manuscript. The last part concludes this communication.

## 2. Back-propagation neural network (BPNN): an overview

As a matter of fact, ANNs attain their name from simple processing units in the brain namely neurons which are mutually connected by a network that conveys signals between them (Chouai et al., 2002; Freeman and Skapura, 1991; Hagan et al., 1996; Piazza et al., 2006). In 1943, the first artificial neuron has been generated by McCulloch and Pitts (McCulloch and Pitts, 1943). A schematic of an artificial neuron is depicted in Fig. 2. The shown neuron  $m$  in Fig. 2 could be illustrated as follows:

$$r_m = \sum_{i=1}^n (w_{mi}x_i + b_m) \quad (1)$$

$$y_m = F(r_m) \quad (2)$$

in which  $x_1, x_2, \dots, x_n$  are the inputs;  $w_{m1}, w_{m2}, \dots, w_{mn}$  show the weights;  $r_m$  is the linear combiner output;  $b_m$  is the bias term;  $F$  is activation function; and  $y_m$  is the neuron's output signal.

ANNs as parallel information processing systems have the remarkable ability to derive linear or nonlinear mathematical relationships by employing a number of input–output training arrangements from given database (Bain, 1873; James, 1890). Commonly, ANNs are adjusted or trained so that desired targets will be yielded from particular inputs. These types of intelligent techniques could be successfully used to deal with many kinds of problems such as prediction, pattern recognition, and classification (Bose and Liang, 1996; Chelgani et al., 2011, 2008; Haykin, 1999; Kasabov, 1996; Looney, 1997; Stamenković et al., 2013). It is generally believed that feed-forward neural networks (FFNNs) including MLPs, functional link networks (FLNs), and radial basis function networks (RBFNs) are robust and credible non-linear classifier recognizer (Looney, 1997).

MLPs, the most popular FFNN employed by chemical, petroleum and natural gas engineers (Ghiasi et al., 2014, 2013), consist of input layer, hidden layer(s) and output layer. Fig. 3 demonstrates a standard three layer MLP network with  $I$  input branching nodes,  $H$  neurons in the hidden layer, and  $O$  output neurons. The number of independent parameters affecting the targets designates the number of input branching nodes. Number of targets defines the number of output layer neurons. Commonly, the optimum number of neurons in the hidden layer(s) is determined by trial and error procedure. The power of MLP network is due to its ability to represent non-linear functions. To incorporate non-linearity into the MLPs, several types of activation functions like threshold transfer function, log-sigmoid transfer function, and tan-sigmoid transfer function could be utilized.

For training the MLP-ANN to adjust the values of synaptic weights between existing computing cells of the network, it is necessary to employ a proper learning algorithm. Back propagation neural network (BPNN), as a popular type of MLP networks, uses the BP learning algorithm to perform training process. BP algorithm is a supervised training paradigm that consists of different training methods. The basic BPNN uses the gradient descent method to minimize the error between the targets and the predictions of the network. Equation (3) represents a cost function,  $e$ , for evaluation of error:

$$e = \frac{1}{2}(t - o)^2 \quad (3)$$

in which  $t$  and  $o$  indicate target value and output of the network, respectively.

Owing to the fact that LM method renders the best performance over other BP algorithms, in this study, BPNN is trained by the Levenberg–Marquardt (LM) technique (Ghiasi, 2012; Ghiasi And Ghayem, in press; Levenberg, 1944; Marquardt, 1963). LM is an iterative solution method that minimizes the sum of squares of errors (Ghiasi, 2012; Press et al., 1992).

## 3. Development of intelligent model to predict TEG purity

The primary purpose of the present study is to develop a BPNN model to estimate TEG purity in gas dehydration systems. Design of BPNN for the application of interest is described step by step in this section. The required data to develop this model includes the reported TEG purity and concentration data as a function of reconcentrator (reboiler) temperature and pressure (Stewart and Arnold, 2011). The operating ranges of gathered database for TEG purity are given in Table 1.

First, all the collected data points from open literature (Stewart and Arnold, 2011) was normalized between 0.105 and 0.805 by employing Equation (4). This pre-processing step has been performed with the aim of modifying the input parameters

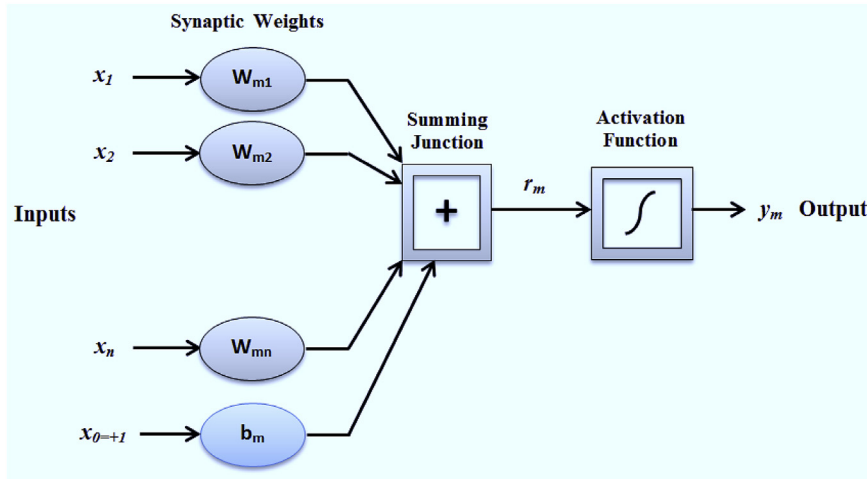

Fig. 2. Typical model of an artificial neuron [33].

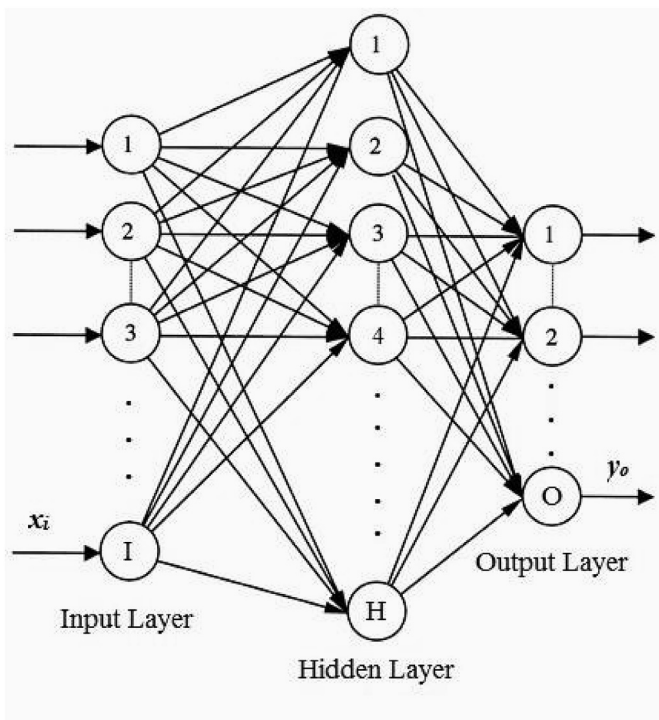

Fig. 3. A typical 3-layer MLP.

distribution to reduce the difference between the network outputs and corresponding target values.

$$b_{\text{norm}} = 0.7 \frac{\ln\left(\frac{(b-b_{\min})}{(b_{\max}-b_{\min})} + 1\right)}{\ln(2)} + 0.15 \quad (4)$$

Table 1  
Operating ranges of collected database for TEG purity.

Parameter	Minimum	Maximum	Mean
TEG purity, wt%	0.954	0.998	0.983
Pressure, kPa	67	122	93.04
Temperature, °C	149	204	174.22

Table 2  
Results of the constructed MLP networks for predicting TEG purity.

Network topology	Training		Validation		Test	
	MSE	R-value	MSE	R-value	MSE	R-value
2-1-1	4.9E-4	0.9882	9.2E-4	0.9495	2.1E-4	0.9442
2-2-1	4.5E-4	0.9880	1.4 E-4	0.9969	1.7 E-4	0.9950
2-3-1	2.9E-4	0.9919	5.4 E-4	0.9984	1.6 E-4	0.9693
2-4-1	2.1E-4	0.9949	1.5 E-4	0.9802	1.4 E-4	0.9551
2-5-1	2.7E-5	0.9993	4.8E-5	0.9988	2.1E-5	0.9996
2-6-1	1.3E-5	0.9996	7.2E-6	0.9998	3.8E-5	0.9994
2-7-1	1.1E-5	0.9997	8.8E-6	0.9997	9.9E-6	0.9998
2-8-1	1.1E-5	0.9997	1.9E-5	0.9998	1.0E-5	0.9997
2-9-1	1.0E-5	0.9997	8.7E-6	0.9994	3.6E-6	0.9998
2-10-1	8.7E-6	0.9998	1.2E-5	0.9993	7.2E-6	0.9999
2-11-1	6.7E-6	0.9998	6.7E-6	0.9998	7.6E-6	0.9988

in which  $b$  is the data which should be normalized;  $b_{\max}$  and  $b_{\min}$  are maximum and minimum of the original data, respectively;  $b_{\text{norm}}$  shows the normalized data which transformed.

The next step constitutes dividing the database into three sub data sets including training data, validation data, and test data. The training dataset is used in learning process to tune the synaptic weights of the constructed network. A drastic problem with neural networks is their tendency to over-fitting. This problem is exaggerated when the model has many parameters. The allocated dataset for validation is employed to avoid developing an over-fitted model. The test set is utilized to evaluate the estimation capability of the built model.

The third step in the modeling procedure is sizing the BPNN structure in order to have the best predictions. A BPNN, as kind of MLP networks, with a single hidden layer (Ghiasi et al., 2013; Ghiasi And Ghayyem, in press; Hornik et al., 1989; Mohammadi and

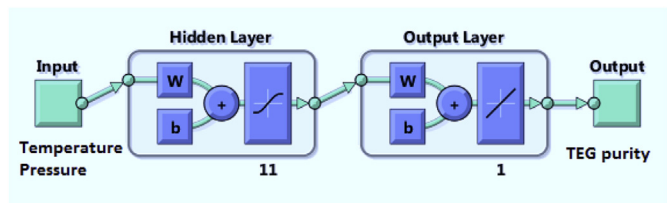

Fig. 4. Structure of the best BPNN for prediction of TEG purity.

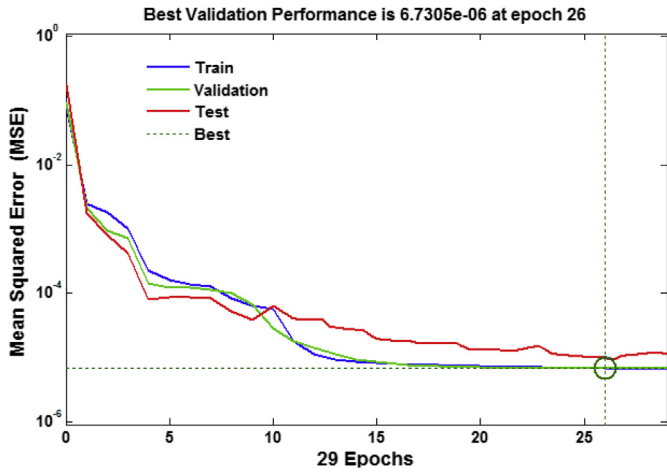

Fig. 5. Performance of the developed BPNN with 2-11-1 topology in estimating the TEG purity.

Richon, 2007; Zendehboudi et al., 2013) has been employed to model the TEG purity,  $\psi$ , as a function of pressure and temperature of the reboiler:

$$\psi = f(T, P) \tag{5}$$

in which  $T$  and  $P$  stand for temperature and pressure of the reboiler, respectively. As previously mentioned, number of input layer branching nodes and number of neurons of the output layer are equal to the independent variables and independent parameters, respectively. However, there is no universal rule to determine the number of hidden neurons. In this work, mean squared error (MSE),

as defined by Equation (6), and R-value are chosen as criteria for investigating the accuracy of constructed networks having different hidden neurons.

$$MSE = \frac{1}{n} \sum_{i=1}^n (t_i - o_i)^2 \tag{6}$$

The last issue is defining the transfer functions of the network. For output layer a linear transfer function has been assigned. The hidden layer uses a tan-sigmoid transfer function. Tan-sigmoid produces outputs between  $-1$  and  $+1$  and it could appear as follows:

$$f(x) = \frac{2}{1 + \exp(-2x)} - 1 \tag{7}$$

#### 4. Results and discussion

The number of hidden neurons of BPNN was varied from 1 to 11 to find the best neural-based model for accurate prediction of TEG purity. For each constructed network both MSE and R-value are measured. The obtained values for the statistical parameters are tabulated in Table 2. According to the Table 2, the best network topology for TEG purity modeling is 2-11-1. The presented BPNN with 2-11-1 structure has the lowest MSE compared to the other developed networks. Furthermore, the values of correlation coefficients for the selected network are sufficiently close to  $+1$ . Graphical illustration of the proposed BPNN structure is shown in Fig. 4. As regards to the number of hidden neurons, it can be concluded that the three layer MLP network trained with BP learning algorithm provides consistently satisfactory predictions when the hidden layers consists of 11 neurons; hence, the

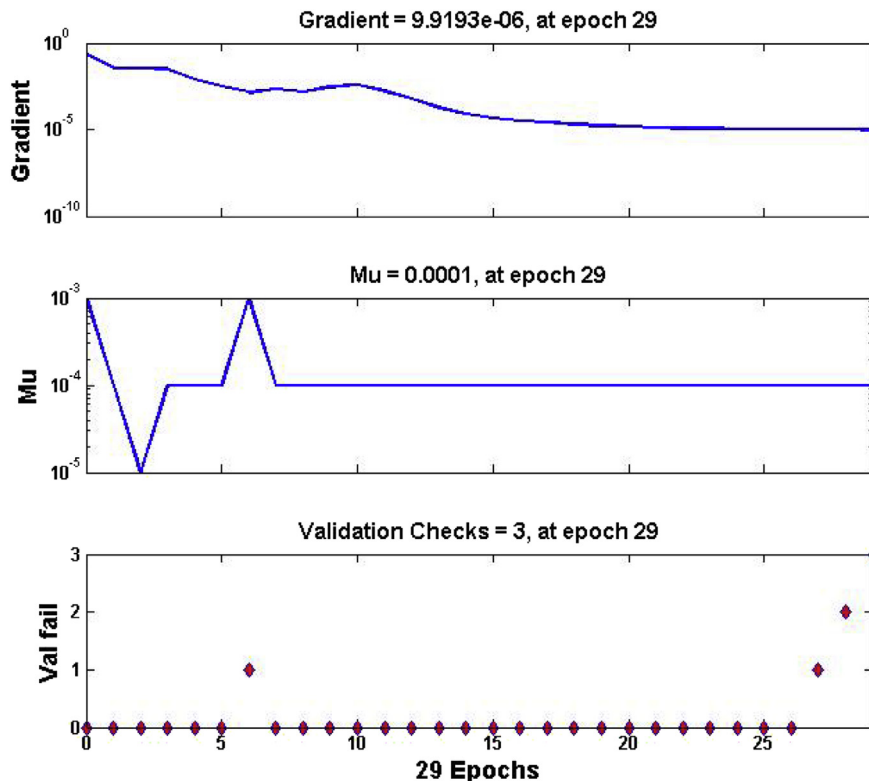

Fig. 6. Training state plot of the best BPNN for TEG purity estimation.

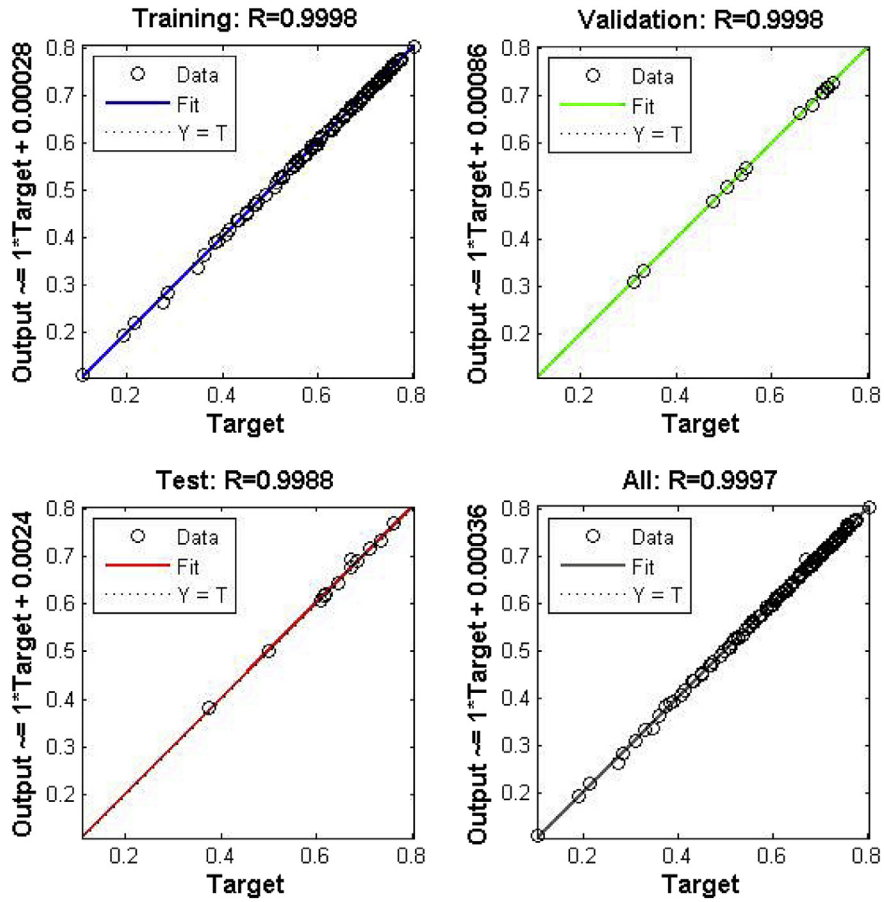

Fig. 7. R-values of training, validation and test sets for selected BPNN.

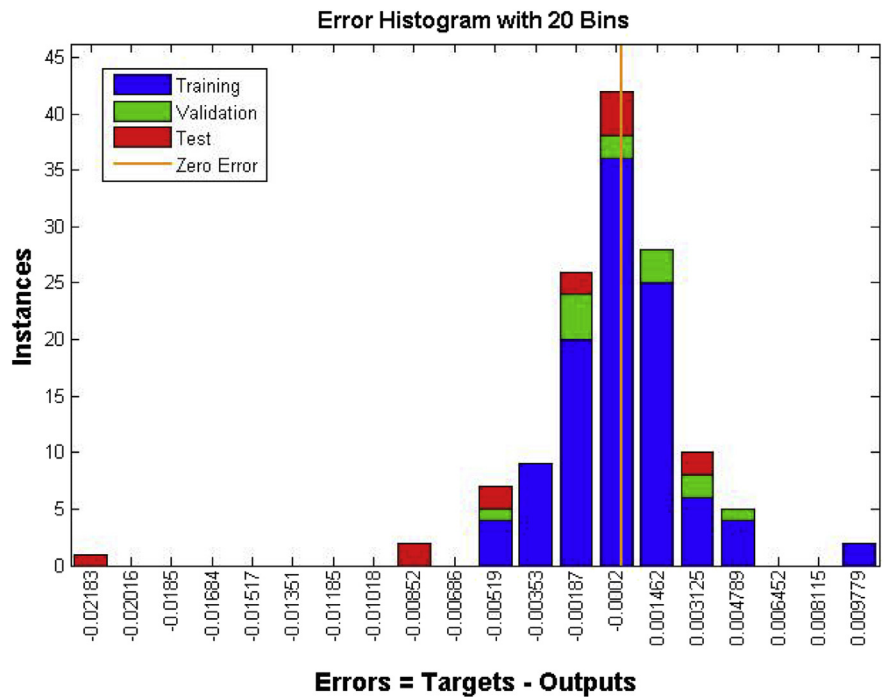

Fig. 8. Histogram of error values for the best BPNN.

performance of networks having more hidden layers are not evaluated in this work.

Fig. 5 shows the estimation capability of the network with 11 neurons in the hidden layer in terms of MSE. Training state plot of the BPNN having optimum number of hidden neurons is provided in Fig. 6. Cross plot of the selected network for training, validation, and test sets is depicted in Fig. 7. Distribution of errors between the reported data for TEG purity (Stewart and Arnold, 2011) and predictions of the best BPNN is demonstrated in Fig. 8. Summary of the best BPNN results for estimation of TEG purity in comparison with some reported data (Stewart and Arnold, 2011) is given in Table 3. As can be seen from Table 3, the predictions of the presented BPNN are in good agreement with the reported data in the literature. With accordance to the fact that the developed BPNN is categorized as a mathematical model, it can be successfully utilized across the operating ranges of the gathered databank.

## 5. Summary and conclusions

In the presented communication, there was a try to model the TEG purity as a function of reboiler (reconcentrator) pressure and temperature by means of ANNs. To this end, the well-proven three-layer MLP-ANN coupled with BP learning algorithm was employed. The BP learning paradigm was trained by the LM iterative method to achieve the best results. The required data for modeling purposes were gathered from reliable literature. Trial and error procedure was employed to find the optimum number of hidden neurons. The best network topology found to be 2-11-1 by monitoring the obtained values of MSE and R-value as performance criterion for different constructed BPNNs. According to the error analysis results, the proposed BPNN with 2-11-1 structure regenerates the training, validation, and test datasets with MSEs being less than  $8 \times 10^{-6}$ .

**Table 3**  
Predictions of the best BPNN in comparison with typical data [17].

Pressure, kPa	Temperature, °C	TEG purity, weight fraction		Absolute deviation percent
		Reported [17]	Predicted	
67	149	0.9780	0.9779	0.01
	160	0.9845	0.9802	0.43
	171	0.9890	0.9869	0.21
	185	0.9926	0.9887	0.39
	204	0.9957	0.9953	0.04
80	154	0.9770	0.9775	0.05
	163	0.9825	0.9795	0.30
	177	0.9882	0.9861	0.21
	182	0.9900	0.9891	0.09
	199	0.9939	0.9930	0.09
	157	0.9745	0.9766	0.21
93	166	0.9810	0.9791	0.19
	174	0.9850	0.9804	0.46
	188	0.9900	0.9821	0.80
	196	0.9917	0.9928	0.10
	101	151.5	0.9667	0.9739
166	166	0.9785	0.9782	0.03
	179.5	0.9857	0.9807	0.50
	190.5	0.9896	0.9821	0.75
	201.5	0.9918	0.9828	0.91
	110	149	0.9590	0.9580
157	157	0.9685	0.9683	0.02
	163	0.9735	0.9764	0.30
	177	0.9870	0.9812	0.59
	188	0.9980	0.9911	0.69
	122	151.5	0.9580	0.9611
166	166	0.9735	0.9734	0.01
	182	0.9840	0.9800	0.40
	193	0.9880	0.9818	0.63
	204	0.9903	0.9923	0.20
	Average absolute deviation percent			

Hence, the predictions of the presented intelligent technique are in good agreement with reported data in open literature.

## Acknowledgments

The first author acknowledges the support from the office of Research & Development at South Pars Gas Complex (SPGC), Asa-luyeh, Iran.

## Symbols used

$b$	The data which should be normalized
$b_{max}$	Maximum of the original data
$b_{min}$	Minimum of the original data
$b_{norm}$	The normalized data which transformed
$b_m$	Bias term
$e$	Cost function
$f$	Activation function
$n$	number of points
$o$	Predicted value
$P$	Pressure, kPa
$r_m$	Linear combiner output
$t$	Target value
$T$	Temperature, °C
$w_{mn}$	Synaptic weight
$x$	data point
$x_n$	Input signal of neuron
$y$	data point
$y_m$	Neuron's output
$\psi$	TEG purity, weight fraction

## References

- Bahadori, A., 2007. New model predicts solubility in glycols. *Oil Gas J.* 105 (8), 50–55.
- Bahadori, A., 2009a. Estimation of hydrate inhibitor loss in hydrocarbon liquid phase. *Pet. Sci. Technol.* 27 (9), 943–951.
- Bahadori, A., 2009b. Rapid estimation of equilibrium water dew point of natural gas in TEG dehydration systems. *J. Nat. Gas Sci. Eng.* 1 (3), 68–71.
- Bahadori, A., Vuthaluru, H.B., 2009a. Simple methodology for sizing of absorbers for TEG (triethylene glycol) gas dehydration systems. *Energy* 34 (11), 1910–1916.
- Bahadori, A., Vuthaluru, H.B., Mokhatab, S., Tade, M.O., 2008. Predicting hydrate forming pressure of pure alkanes in the presence of inhibitors. *J. Nat. Gas Chem.* 17, 249–255.
- Bahadori, A., Vuthaluru, H.B., 2009b. New method accurately predicts carbon dioxide equilibrium adsorption isotherms. *Int. J. Greenh. Gas Control* 3, 768–772.
- Bahadori, A., Zahedi, G., Zendejboudi, S., Jamili, A., 2014. A new method estimates TEG purity versus reconcentrator temperature at different levels of pressure in gas dehydration systems. *Int. J. Oil Gas Coal Technol.* 7 (1), 85–94.
- Bain, A., 1873. *Mind and Body: the Theories of Their Relation*. D. Appleton and Company, New York.
- Bose, N.K., Liang, P., 1996. *Neural Network Fundamentals with Graphs, Algorithms, and Applications*. McGraw-Hill Series in Electrical and Computer Engineering. McGraw-Hill, USA.
- Chelgani, S.C., Hower, J.C., Hart, B., 2011. Estimation of free-swelling index based on coal analysis using multivariable regression and artificial neural network. *Fuel Process. Technol.* 92 (3), 349–355.
- Chelgani, S.C., Hower, J.C., Jorjani, E., Mesroghli, S., Bagherieh, A.H., 2008. Prediction of coal grindability based on petrography, proximate and ultimate analysis using multiple regression and artificial neural network models. *Fuel Process. Technol.* 89 (1), 13–20.
- Chouai, A., Laugier, S., Richon, D., 2002. Modeling of thermodynamic properties using neural networks: application to refrigerants. *Fluid Ph. Equilib.* 199 (1–2), 53–62.
- Freeman, J.A., Skapura, D.M., 1991. *Neural Networks: Algorithms, Applications, and Programming Techniques*. Computational and Neural Systems. Addison-Wesley Publishing Company, USA.
- Gharagheizi, F., Eslamimanesh, A., Mohammadi, A.H., Eskandari, S., Richon, D., 2013. Assessment test for glycol loss in gaseous system. *Fuel Process. Technol.* 115 (0), 254–260.
- Ghiasi, M.M., 2012. Initial estimation of hydrate formation temperature of sweet natural gases based on new empirical correlation. *J. Nat. Gas Chem.* 21, 508–512.

- Ghiasi, M.M., Bahadori, A., Zendejboudi, S., 2014. Estimation of the water content of natural gas dried by solid calcium chloride dehydrator units. *Fuel* 117 (Part A(0)), 33–42.
- Ghiasi, M.M., Bahadori, A., Zendejboudi, S., Jamili, A., Rezaei-Gomari, S., 2013. Novel methods predict equilibrium vapor methanol content during gas hydrate inhibition. *J. Nat. Gas Sci. Eng.* 15 (0), 69–75.
- Ghiasi, M.M., Ghayyem, M.A., 2014. Application of artificial neural network (ANN) in prediction of hydrate formation temperature (in press). *Energy Sources Part A Recovery Util. Environ. Eff.*
- Ghiasi, M.M., Mohammadi, A.H., 2013. Determination of methane-hydrate phase equilibrium in the presence of electrolytes or organic inhibitors by using a semi-theoretical framework. *Energy Technol.* 1 (9), 519–529.
- Gironi, F., Maschietti, M., Piemonte, V., 2010. Natural gas dehydration: a triethylene glycol-water system analysis. *Energy Sources Part A Recovery Util. Environ. Eff.* 32 (20), 1861–1868.
- GPSA, 2004. Gas Processors Suppliers Association, USA.
- Hagan, M.T., Demuth, H.B., Beale, M., 1996. *Neural Network Design*. PWS Publishing Company, USA.
- Haykin, S.S., 1999. *Neural Networks: A Comprehensive Foundation*. Prentice Hall International.
- Hornik, K., Stinchcombe, M., White, H., 1989. Multilayer feedforward networks are universal approximators. *Neural Netw.* 2 (5), 359–366.
- James, W., 1890. *The Principles of Psychology*. Holt and Company, New York.
- Kasabov, N.K., 1996. *Foundations of Neural Networks, Fuzzy Systems, and Knowledge Engineering*. MIT Press.
- Levenberg, K., 1944. A method for the solution of certain non-linear problems in least squares. *Q. Appl. Math.* 2 (2), 164–168.
- Looney, C.G., 1997. *Pattern Recognition Using Neural Networks, Theories and Algorithms for Engineers and Scientists*. Oxford University Press, USA.
- Lubnau, U., Mothes, R., 2009. Regeneration of triethylene glycol (TEG) with inorganic membranes GWF. *Gas Erdgas* 150 (12), 752–757.
- Marquardt, D.W., 1963. An algorithm for the least-squares estimation of nonlinear parameters. *SIAM J. Appl. Math.* 11 (2), 431–441.
- Masoudi, R., et al., 2005. Measurement and prediction of gas hydrate and hydrated salt equilibria in aqueous ethylene glycol and electrolyte solutions. *Chem. Eng. Sci.* 60 (15), 4213–4224.
- McCulloch, W., Pitts, W., 1943. A logical calculus of the ideas immanent in nervous activity. *Bull. Math. Biophys.* 5 (4), 115–133.
- Mohammadi, A.H., Richon, D., 2007. Use of artificial neural networks for estimating water content of natural gases. *Ind. Eng. Chem. Res.* 46 (4), 1431–1438.
- Mohammadi, A.H., Samieyan, V., Tohidi, B., 2005. Estimation of water content in sour gases. In: *SPE Europec/EAGE Annual Conference Madrid, Spain*.
- Nivargi, J.P., Gupta, D.F., Shaikh, S.J., Shah, K.T., 2005. TEG contactor for gas dehydration. *Chem. Eng. World* 40 (9), 77–80.
- Piazza, L., Scalabrin, G., Marchi, P., Richon, D., 2006. Enhancement of the extended corresponding states techniques for thermodynamic modeling. I. Pure fluids. *Int. J. Refrig.* 29 (7), 1182–1194.
- Piemonte, V., Maschietti, M., Gironi, F., 2012. A triethylene glycol–water system: a study of the TEG regeneration processes in natural gas dehydration plants. *Energy Sources Part A Recovery, Util. Environ. Eff.* 34 (5), 456–464.
- Press, W.H., Teukolsky, S.A., Vetterling, A.W.T., Flannery, B.P., 1992. *Numerical Recipes in C: the art of Scientific Computing*. Cambridge University Press, USA.
- Stamenković, O.S., Rajković, K., Veličković, A.V., Milić, P.S., Veljković, V.B., 2013. Optimization of base-catalyzed ethanolsynthesis of sunflower oil by regression and artificial neural network models. *Fuel Process. Technol.* 114 (0), 101–108.
- Stewart, M., Arnold, K., 2011. *Gas Dehydration Field Manual*. Gulf Professional Publishing, MA, USA.
- Wichert, E., Wichert, G.C., 2004. New charts estimate acid gas solubility in TEG. *Hydrocarb. Process.* 83 (1), 47–48.
- Zendejboudi, S., Ahmadi, M.A., Bahadori, A., Shafiei, A., Babadagli, T., 2013. A developed smart technique to predict minimum miscible pressure—eor implications. *Can. J. Chem. Eng.* 91 (7), 1325–1337.