

# Novel Stability Enhancing Control Strategy for Centralized PV-Grid Systems for Smart Grid Applications

Rupesh G. Wandhare, *Student Member, IEEE*, and Vivek Agarwal, *Senior Member, IEEE*

**Abstract**—Inverter driven, inertia-less interface of a large photovoltaic (PV) source with power grid raises challenging penetration issues such as bus voltage fluctuation, active power variation, reactive power flow and poor system dynamics. Extensive efforts are underway to overcome these issues, which tend to put a limit on the maximum PV power injection capability for a given local area electric power system. This paper proposes a new control scheme that enables a centralized PV-grid system to damp out the low frequency power swings on the local area network as an ancillary activity apart from its regular function. The proposed scheme enhances the power system stability without incorporating any additional devices or systems (e.g., PSS). The analytical basis of the control law used in this scheme is derived from the structure preserving energy function (SPEF) model. A notable feature of the scheme that makes it highly feasible is that it requires only locally measurable signals. Further, it does not affect the MPPT control of the PV system in any manner. All these features make it highly relevant and suitable for smart grid applications. Relevant simulation results as well as key experimental results for a laboratory level hardware model are included.

**Index Terms**—Control law, DC-AC power converters, distributed power generation, power system stability, solar power generation, structure preserving energy function.

## I. INTRODUCTION

THE SUN IS THE ultimate source of energy and it is widely felt that if solar energy is prudently tapped using solar photovoltaic (PV) technology, it can meet all the energy requirements of the mankind. Both crystalline and thin film PV technologies have evolved at tremendous pace, rendering solar PV amongst the most popular alternatives to fossil fuel based conventional energy. Extensive research efforts in the area have led to the possibilities of integrating large, centralized PV generation (CPVG) with the power grid. This, coupled with considerable reduction in PV panel prices, has raised unprecedented interest in this area. CPVG has a huge potential to serve as a large capacity electric energy source [1]. Many countries have already embarked upon ambitious missions of integrating large capacity CPVG with their power grid. In fact, the CPVG can be assigned additional (ancillary) functionalities as part of smart grid structure [2].

The accumulation of a large number of PV-grid systems, especially the CPVG's, have led to new challenges and issues

such as power system stability, grid voltage profile and regulation and power quality. These factors impose an upper limit on the PV penetration for a given capacity feeder or small capacity system. This limit is to guarantee that, the operating parameters are within rated specifications, even under dynamical disturbances to secure both utility and PV distributed generation system (PV-DGS) [3]. This paper focuses on the stability aspect of the power grid under large PV penetration.

Talking about stability, a major issue arises on account of the “inertia-less” nature of the power inverters which are used to interface the solar PV with the grid. Although competitive interest for integration of large capacity photovoltaic sources to the grid has resulted in several highly efficient versions of inverters and control schemes—the inertia less interfacing of VSI based PV-DGS continues to impose many limitations on the use of conventional form of inverter control.

Conventional power system stabilizers (e.g., governor, AVR etc.) associated with generating stations continue to be the mainstay of a power system's dynamic stability [4]. However, with advancement in technology, FACTS devices (eg. SSSC, SVC, STATCOM, etc.) are now commonly used for further enhancing the dynamic stability of the power system [5]–[8]. They are used to damp out the low frequency electromechanical oscillations arising due to disturbances in weak systems. Yet, a wide deviation of power angle and prolonged oscillations may result in the system falling out of step or getting bifurcated into small islands. In the smart grid scenario, this is one of the challenging domains where inertia-free renewable energy sources are coupled to the grid, e.g., high penetration PV systems [9], [10].

Adverse effects of high penetration of large capacity PV sources on the dynamic stability of power system have been studied by some researchers [10]–[12]. Yazdani *et al.* [13] have presented the modeling procedure of a large PV system to analyze and identify the potential issues with high PV penetration. Du *et al.* [11] have reported that conventional control of PV generating stations, exceeding a critical penetration limit, induces negative damping torque. Other authors [12] have presented case studies of large PV sources penetrating the conventional power system and have concluded that the power system's ability to handle electromechanical oscillations reduces with increasing penetration levels. Working on similar lines, some other authors [10] have concluded that 20% PV penetration causes large oscillations of relative power angles between generators followed by fault initiated transients.

Other challenging issues associated with large PV penetration, such as voltage variations of load buses and reverse power flow due to the intermittent nature of solar energy, have

Manuscript received April 19, 2013; revised July 16, 2013; accepted August 13, 2013. Paper no. TSG-00308-2013.

The authors are with Department of Electrical Engineering, Indian Institute of Technology—Bombay, Mumbai, Maharashtra, India, 400076.

Color versions of one or more of the figures in this paper are available online at <http://ieeexplore.ieee.org>.

Digital Object Identifier 10.1109/TSG.2013.2279605

also been reported by some authors [14]–[16]. They have concluded that the prevailing standards, e.g., IEEE 1547 [3] need appropriate amendments to accommodate advancements in control techniques of the conventional PV-grid system. Some researchers [17] have determined the fault current levels in the presence of large grid tied PV inverters (PV-DGS) while others [1] have discussed the planning of generation, scheduling and power dispatch in the presence of large centralized PV-grid systems. Limited literature is available that discusses the ancillary functionality of DGS for dynamic stability enhancement. Almost all the reported work is based on active power control that requires reliable sources, e.g., fuel cell [18]. Some other authors [2], [19] have recommended modernization of the power grid in the environment of FACTS and DGS by assigning additional functionalities to them for power system security.

Overall it is observed that the existing literature mainly discusses the consequences of high PV power injection into the power system and failure of the system parameters under these conditions. To the best of authors' knowledge, there are not many suggestions or proposals on alternate, better control schemes that would allow higher PV power injection into the existing system without any adverse effects. Moreover, the proposals for enhancing the PV station capacity to integrate with the grid require heavy modification of the infrastructure and integration of energy storage.

The presented work focuses on how to improve the dynamic stability of the system in the presence of large capacity PV-DGS. This is achieved by using a special control law that is analytically derived from the structure preserving energy function (SPEF) model. The designed controller works with only locally measurable signals. Hence, it is easy to acquire and integrate them into the system. In addition, the proposed technique is independent of the location of the PV source installation in the system and does not disturb active power control including MPPT. In view of the increasing demand to revise the existing standards, it is fair to assume that in the imminent future dominated by smart grid, it will be possible to operate large PV installations by suitably controlling the critical power system parameters, at least during the transient phase.

## II. USE OF FACTS FOR DYNAMIC STABILITY

Advancement in FACTS technology [20] has facilitated a drastic increase in the power flow capability, transient stability, power oscillation damping, and sub-synchronous resonance mitigation to name just a few. Amongst the FACTS, shunt type devices such as static VAR compensator (SVC) [Fig. 1(a)] and its derivatives and static synchronous compensator (STATCOM) [Fig. 1(b)] are mainly used to provide reactive power compensation or to regulate the voltage of the bus to which they are connected. Apart from this, their application in damping the low frequency power oscillations has also been investigated [7], [20], [21].

The general mechanism of inter-area or local area power swing damping using FACTS is based on local measurements with estimation of remote parameters using the developed model. The simplified/approximate model runs on real time basis which takes a finite time. Further, any modification in the system leads to unpredictable results. To overcome the issues with the control based on power system model, recently, phasor measurement units (PMU) have been installed at statistical

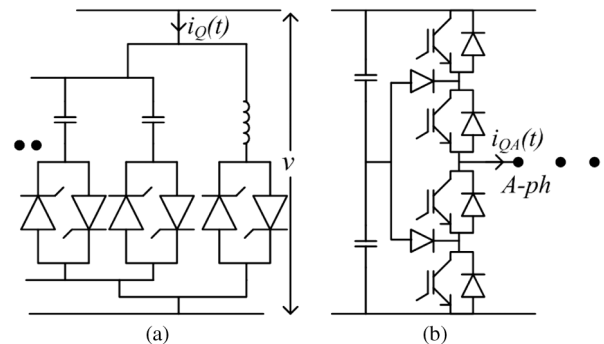

Fig. 1. (a) Thyristor switch capacitor-thyristor controlled reactor (TSC-TCR) VAR compensator. (b) A-ph of the STATCOM for VAR compensation.

locations in the utility [22], [23] to measure and transfer conditioned data to the phasor data concentrator (PDC). SVC and STATCOM utilize the states derived by the PDC for damping electromechanical oscillations. Clearly, the system performance is totally dependent upon the accuracy of the transmitted data and may be prone to communication error/noises.

The conventional methods of control for power oscillation damping use measured or estimated values of power flow variation or frequency deviation to control the variation in power transmission angle  $\delta$  as per the following relations.

$$\frac{d\Delta\delta}{dt} \propto \int P_a(t)dt \quad (1)$$

$$\frac{d\Delta\delta}{dt} \approx \Delta f_T \quad (2)$$

where  $P_a(t)$  is the accelerating power associated with the line or generator.

Commonly used SVC and STATCOM and their properties are briefly described next. Later, in this paper, it is demonstrated how a PV-DGS interface inverter, having the same structure as that of a STATCOM, can be used to perform ancillary duties such as damping of electromechanical oscillations.

### A. Static Voltage Compensator (SVC)

The SVC utilizes the traditional high current and high voltage rating devices like a thyristor (SCR) and hence the number of devices required is much less compared to a STATCOM of comparable rating. However, time lag delay in the SVC is significantly high and it results in poor dynamic response. Further, the SVC introduces harmonics during operation. Maximum attainable compensating current of SVC is a function of voltage and maximum VAR decreases with square of the voltage.

### B. Static Synchronous Compensator (STATCOM)

The STATCOM requires fully controlled power devices such as GTO, IGBT, etc., which are more expensive. They also have limited ratings compared to an SCR because of which a large number of devices are required. However, the STATCOM can provide a wider bandwidth and can be designed for most of the controlling parameters of the targeted system. Independent real and reactive power control of the STATCOM with energy storage makes it highly effective in improving the dynamic stability of the system without injecting harmonics beyond permissible limits. The compensating reactive component of current in STATCOM is almost independent of the voltage variation and can operate at very low AC bus voltage. The ability of providing

both leading and lagging reactive power with fast step-less control makes STATCOM an ideal shunt compensator for dynamic stability enhancement.

Due to the aforesaid properties, STATCOM stands out as a superior device for dynamic stability enhancement except that its cost is high. A major issue with using STATCOM for electromechanical oscillation damping is the requirement of “tie line power flow” as an observable signal for feedback. Control schemes based on remote signals [21], [24] are not recommended due to their low reliability and vulnerability to noise. Further, any network upgradation would require re-tuning of at least some parameters if such a scheme is used. To overcome some of these issues, STATCOM with locally available feedback control has also been investigated [5], [6]. However, a dedicated STATCOM is not really economical for the rarely occurring power swing events.

In the backdrop of the ongoing discussion, this paper proposes the use of PV-DGS (having similar structure as that of STATCOM) for dynamic stability enhancement by damping electromechanical oscillations. Only the locally acquired signals are required for this ancillary duty, which are, in fact, a sub-set of the signals anyway used by the PV-DGS for its main function, i.e., active power control. Further, no additional power circuit or modifications are required for the PV-DGS to carry out this ancillary activity and active power control with MPPT remains totally unaffected. Enhancement of the PV inverter’s utilization factor is an added advantage.

### III. SYSTEM DESCRIPTION UNDER STUDY

Solar PV generating stations in tens of MW range are nowadays common and typically include a cluster of several 2.5 to 3 MW solar inverters. These installations are integrated with the power system at medium or high voltage transmission line through a step up transformer. Without any loss of generality, an entire cluster of inverters constituting a PV station may be treated as one big centralized voltage source inverter (CVSI), to study the impact of PV station interface with the power system.

A “two machine” system, with 100 MW generators, has been considered in this work, as shown in Fig. 2, along with the double line transmission model popularly used in power system stability study and the study of other system parameters including protection co-ordination [25]. The generator sets are supported by governors and AVRs. A PV station of 30 MW capacity is assumed to be tied to the middle of one of the transmission lines through a 34 MVA inverter. The excess capacity of the inverter is meant for accommodating reactive power component.

In this study, it is assumed that generator-1 provides constant power and voltage while generator-2 is operated with voltage and floating power control so as to achieve power balance under steady state. Fig. 2 also shows machine reactances, line parameters, breakers, power angles, and phase angles with respect to the center of inertia. No supplementary stability enhancing equipment is assumed to be connected in the system.

### IV. CONTROL DESIGN AND STRATEGY

Power system issues such as disturbances, protection coordination and relay settings, power system stabilizer design, etc., can be investigated using energy function analysis [5], [25]. Considerable work is available on the application of SPEF with

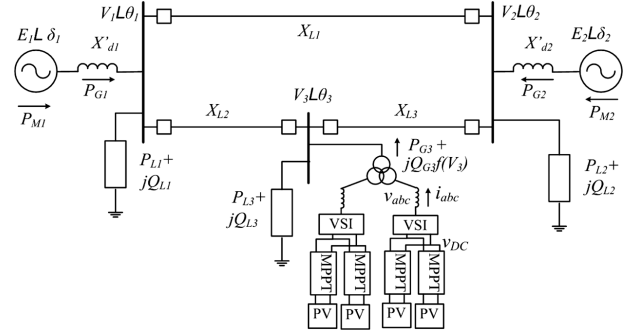

Fig. 2. A “two machine double transmission line” model under study with a large centralized PV source interface.

FACTS devices for further enhancement of dynamic stability [5], [8], [26]. Some authors [27], [28] have demonstrated its use with a different approach for power system stability. Some other researchers [8] have highlighted the benefits of SPEF on account of its modularity and applicability to power system comprising several FACTS devices. In this paper, a structure preserving energy function (SPEF) model is used to derive the control law for a PV-grid system to facilitate stability enhancement. The SPEF model of a system is given by (and used for further analysis):

$$v(\tilde{\omega}, \tilde{\theta}, \tilde{V}) = \frac{1}{2} \sum_{i=1}^m M_i \tilde{\omega}_i^2 - \sum_{i=1}^m P_{Mi}(\tilde{\delta}_i - \tilde{\delta}_{oi}) + \sum_{i=1}^n P_{Li}(\tilde{\theta}_i - \tilde{\theta}_{oi}) + \sum_{i=1}^n \int_{V_{oi}}^{V_i} \frac{Q_i(V_i)}{V_i} dV_i + \frac{1}{2} \sum_1^{line} Q_{series} \quad (3)$$

where  $m$  is the number of generator buses and  $n$  is the number of load buses.  $Q_{Series}$  is the reactive power in all series branches. The suffix “o” denotes steady state values. Power angles and phase angles are measured with respect to the center of inertia.  $Q_i(V_i)$  denote the reactive power functions associated with various buses and reactive power controlling devices such as PV-grid inverter, DVR, SVC, STATCOM etc.

The SPEF model (3) can be suitably modified for the system under study (Fig. 2), which upon differentiation with respect to time yields the following:

$$v'(\tilde{\omega}, \tilde{\theta}, \tilde{V}) = \underbrace{\sum_{i=1}^2 M_i \dot{\tilde{\omega}}_i \tilde{\delta}_i}_A - \underbrace{\sum_{i=1}^2 P_{Mi} \dot{\tilde{\delta}}_i}_B + \underbrace{\sum_{i=1}^3 P_{Gi} \dot{\tilde{\delta}}_i}_C + \underbrace{\sum_{i=1}^3 P_{Li} \dot{\tilde{\theta}}_i}_D + \underbrace{\sum_{i=1}^3 Q_i(V_i) \frac{\dot{V}_i}{V_i}}_E + \underbrace{\frac{d}{dt} \int_{V_{og}}^{V_g} \frac{-I_{Qg} V_g}{V_g} dV_g}_F + \underbrace{\frac{d}{dt} \frac{1}{2} \sum_1^{line} Q_{Line}}_G \quad (4)$$

where  $I_{Qg}$  is the PV station reactive power component.

Various terms of (4) are marked “A” through “G” for easy referencing. The damping components of (4) can be identified from the various terms which can then be used to damp oscillations during a disturbance as explained later. The sufficient condition for effectively damping the electromechanical oscillations is that the time derivative of total energy function must be negative, i.e., for  $v(\tilde{\omega}, \tilde{\theta}, \tilde{V}) > 0$ ,  $v'(\tilde{\omega}, \tilde{\theta}, \tilde{V}) \leq 0$ . The energy released during a disturbance must decrease with time to ensure damping of power oscillations.



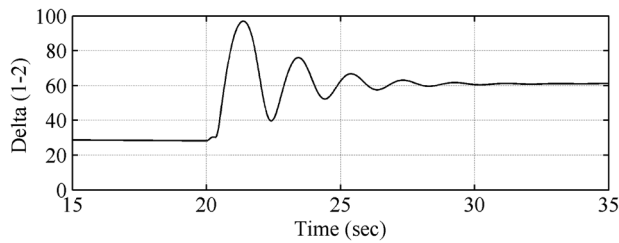

Fig. 4. Simulation result for power angle between buses 1-2 corresponding to an L-G fault with conventional control of PV source.

time windows. Various types of transitory faults are created at different locations to trigger disturbances followed by corrective action of the breakers. The system response to the disturbance is studied with and without the proposed control strategy. The study is organized into two cases based on two different types of faults during high power transfer condition through the double line system, created by connecting a lump load of 210 MW on the right side generator bus (Fig. 2). The input to the PV model is set so as to contribute 20 MW power to the grid for this study.

*Case-I: L-G Fault on the Upper Transmission Line:* In this case study, the more frequently occurring L-G fault is simulated to trigger dynamic disturbance and the behavior of PV-DGS is studied with and without the proposed scheme.

*a) Without proposed control scheme:* As shown in Fig. 4, the fault is introduced at time instant  $t = 20$  s, which is followed by breaker corrective action. The breaker opens the faulted line before the system loses synchronism. However, in the absence of the proposed controller (which is akin to the conventional PV grid interface), long lasting electromechanical oscillations are visible because of a wide variation in the phase angle between the two long distance buses 1-2. It causes severe adverse impact on the equipment connected to these lines as well as the nearby buses.

*b) With proposed control scheme:* The proposed control strategy of dynamic stability enhancement is now activated in the PV-DGS model and a fault condition, identical to Case-I(a), is generated for further investigations. Fig. 5(a) shows that the controller significantly reduces the electromechanical oscillations compared to Case-I(a). The oscillating modes, corresponding to the power swing (or disturbance), are clearly visible in the station bus voltage. Therefore use of station bus voltage as feedback signal for dynamic stability enhancement is justified. Though steady state reactive power compensation or active bus voltage regulation is possible by the PV station VSI, the proposed control strategy is intended only to effectively dampen the electromechanical oscillations. The washout and low pass filters have been used to derive the feedback signal for the control law which further generates the reference current  $i_{qe}^*$  for VSI as shown in Fig. 5(c) and 5(d). The current driven by the proposed control strategy is responsible for the effective energy control during the period of fault and immediately after that. In the present case, this is achieved by the component of station injected current corresponding to the reactive power. Fig. 5(e) shows the active and reactive power contribution by the PV generating station during steady state and disturbance. The results validate the de-coupling between active power and dynamically controlled reactive power.

As shown in Fig. 5(a), the peak of power angle between the lines is reduced, facilitating a significantly longer “critical

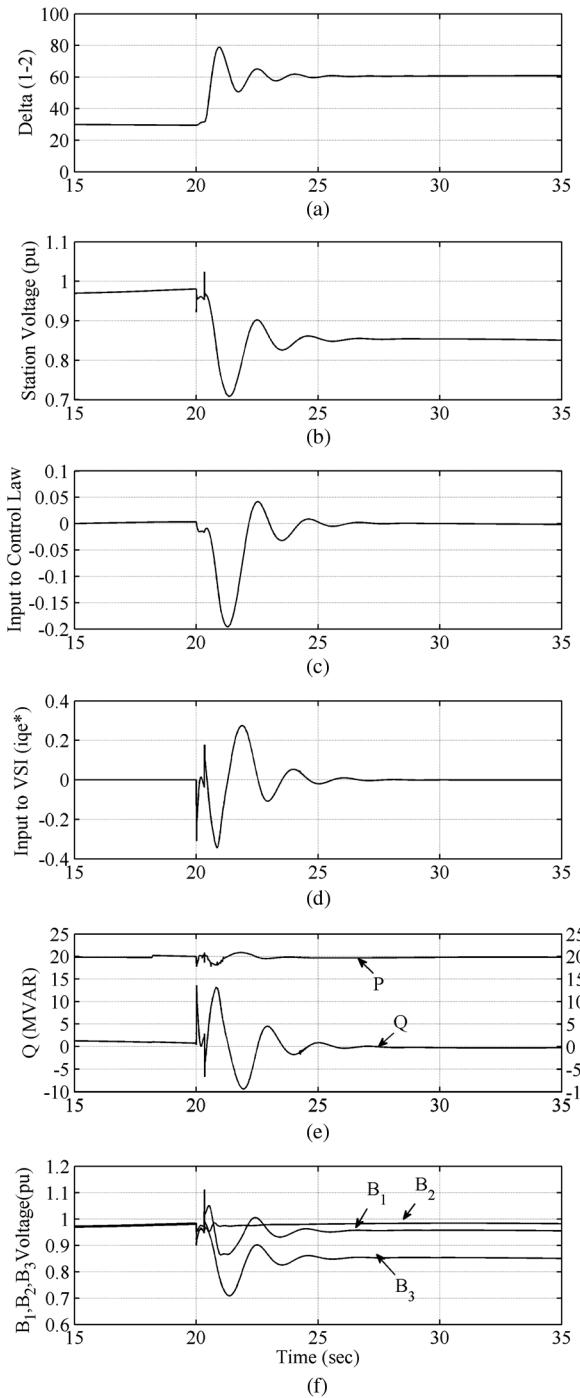

Fig. 5. Simulation results for the proposed control strategy corresponding to an L-G fault: (a) power angle between buses 1-2; (b) PV station voltage; (c) input to the control law after low-pass and washout filters; (d) reference current generated by the controller for reactive power component of current; (e) actual reactive and active power injection by the PV station, and (f) power system bus voltages.

clearing time” during a fault. In short, the proposed control scheme provides more margin for clearing a fault in a natural manner.

*Case-II: 3-Phase Fault on the Upper Transmission Line:* In this case study, the most severe three phase fault is simulated to study its impact on the weak power system with and without using the control law.

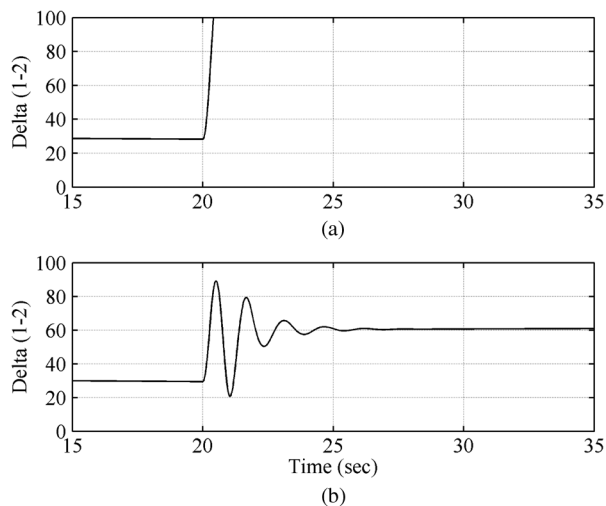

Fig. 6. Simulation results for power angle between buses 1-2 corresponding to a 3-phase fault: (a) with conventional control of PV source; (b) with the proposed control strategy.

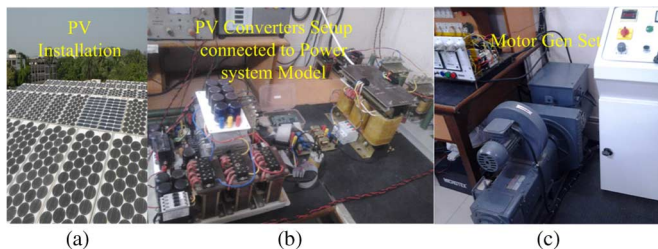

Fig. 7. Hardware setup for the verification of proposed control strategy: (a) PV facility; (b) hardware setup; (c) weak power system model with synchronous machine.

*c) Without proposed control scheme:* A three phase fault is simulated on the same location and breaker operates in the same time as in case-I. With the conventional PV station control in the presence of a 3-phase fault, the system falls out of step quickly and becomes unstable. Fig. 6(a) shows the phase angle between the two long distance buses 1-2. As may be observed in the figure, the critical clearing time is much less in this case.

*d) With proposed control scheme:* The proposed dynamic stability enhancement controller is now activated and the three-phase fault is simulated again, keeping all other conditions unchanged. The corresponding simulation result is shown in Fig. 6(b). It is observed that the system doesn't lose its rigidity and remains dynamically stable in the face of the 3-phase fault. The electromechanical oscillations also die down quickly.

From the presented simulation studies, it is clear that the proposed control strategy for the centralized PV generating station offers additional PV penetration margin for the given location of the plant in the system, in spite of its physical inertia-less property.

## VI. EXPERIMENTAL VERIFICATION

Fig. 7 shows the various components of the experimental test-bench developed for verifying the proposed control law. The weak power system is emulated by a synchronous generator connected to the power grid with a large line inductance. A

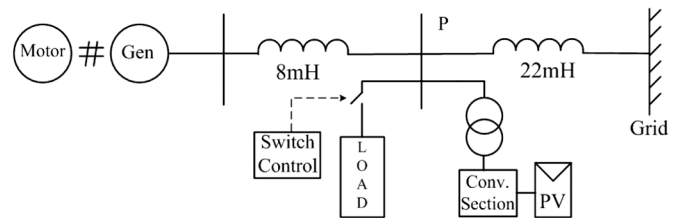

Fig. 8. A low power level set-up for the experimental study of the dynamic stability improvement using the proposed scheme.

1.5 kW available PV facility is interfaced with this weak grid through an inverter.

PV modules are configured in series and parallel so as to achieve an array voltage of 220 V near the MPP. A boost converter, operated as per “Incremental conductance MPPT” algorithm, is interfaced with the DC link input of the VSI. The DC link voltage is regulated at 380 V. A 3 kVA PV inverter (and filter) is designed and connected to a 3-Ph, 400 V weak power system through a 440/220 V, Y/ $\Delta$  transformer as shown in Fig. 8. The connection point “P” is considered sufficiently close to the generator side to ensure PV power feeding into the weaker section of the power line. The proposed control strategy is discretized and coded into the TMS320F2812 DSP development board controlling the PV generating system. The software protections are incorporated using the same feedback signals from the field as the ones used for controlling the interface. In addition, redundant hardware protection is provided where ever possible.

A 3-Ph, 5 kW, 415 V, Y-connected synchronous machine driven by DC motor is used as the far-end generator connected to the grid with high inductance line. The conventional synchronization method is used for interfacing the synchronous machine with the grid. The speed of DC motor as prime mover and terminal voltage of the generator are controlled for machine synchronization. The controllable load is used to create the disturbances for further study. This arrangement provides an adequately safe means for transient study at laboratory level. The inertia constant for the machine set is given as  $H = 0.84$ , thus the filter time constants in the control strategy are tuned accordingly. Significant power transfer condition is established in the line such that the synchronous generator contributes 2.2 kW power while PV source generates power corresponding to the MPP as per the existing environmental conditions. The generator terminal voltage and injected current are shown in Fig. 9(a). The current waveform includes harmonic contents because of distortion in laboratory supply voltage (due to a slightly flat topped grid supply) compared to the high quality voltage generated by the synchronous machine. Phase-A terminal voltage and current injected by the PV-DGS system are shown in Fig. 9(b).

Series of experiments were performed by repeatedly turning ON a 1.8 kW load using a load control system developed in LABView. The machine current was monitored while carrying out disturbance study using the conventional means of control of the PV generating station. The results are shown in Fig. 9(c) on a larger time-scale of 250 ms/div. It shows that the system experiences severe oscillations before settling down to the steady state using the conventional PV-DGS control, where only active power is contributed to the grid as shown in Fig. 9(d). No change is observed in the amplitude of the current injected by the PV system.

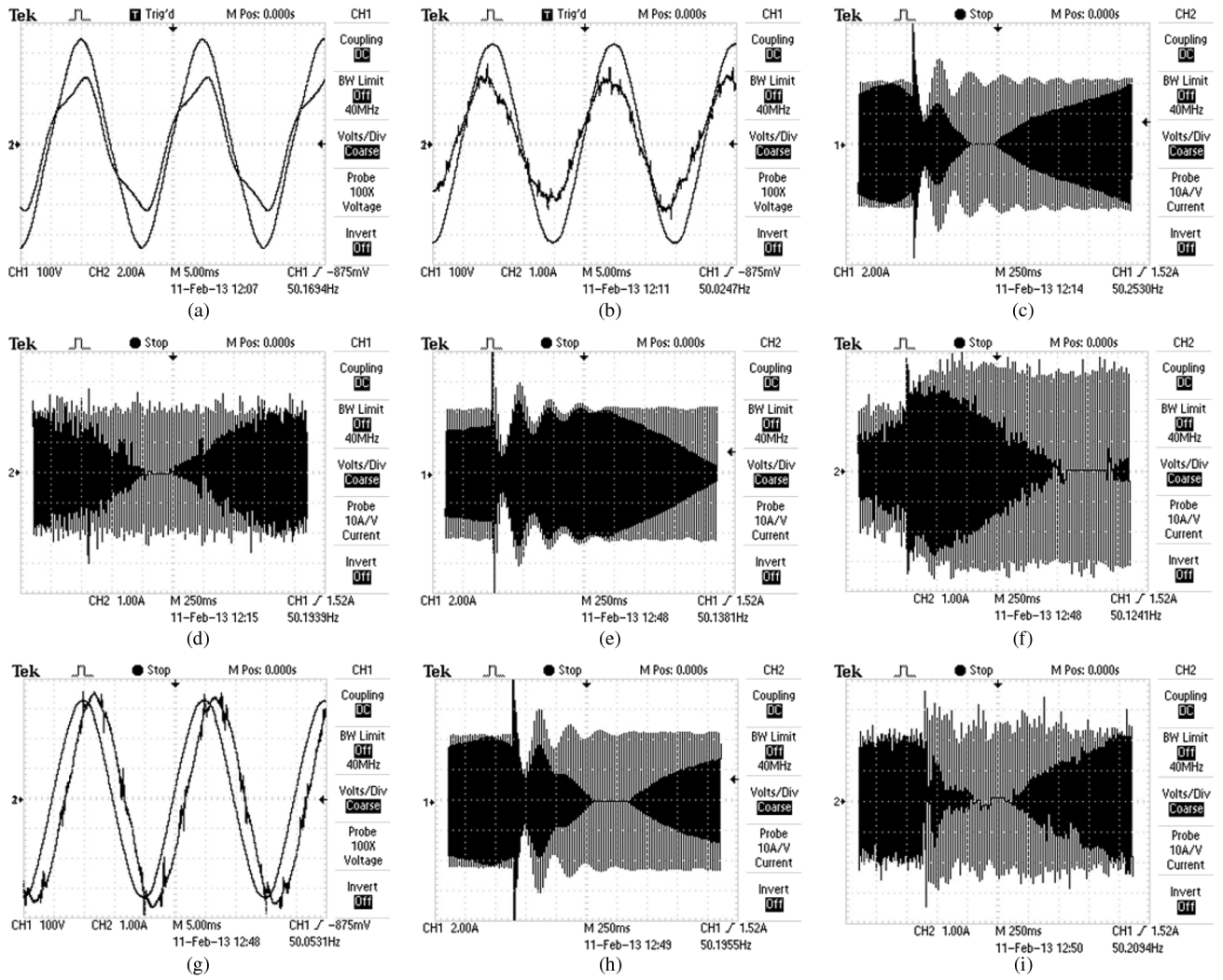

Fig. 9. Experimental results obtained from the system of Fig. 8: (a) generator voltage and current for phase-A; (b) PV inverter voltage and current for phase-A measured at transformer HV side; (c) A-phase generator current under disturbance without the proposed control law (on larger time scale); (d) A-phase PV inverter current response with conventional control; (e) A-phase generator current under disturbance with voltage regulation scheme; (f) A-phase PV inverter current response with voltage regulation scheme; (g) A-phase PV inverter current response with voltage regulation scheme (on magnified time scale); (h) A-phase generator current under disturbance with proposed control scheme; (i) A-phase PV inverter current response with proposed control scheme.

In the second case, the PV-DGS system was used to regulate the AC bus voltage to benchmark and compare the effectiveness of the proposed control law. The results are shown in Figs. 9(e) through 9(g). It is observed from Fig. 9(e) that by controlling reactive power component current,  $i_q$  for AC bus voltage regulation, electromechanical oscillations do get suppressed [5], [32]. Additional loads in the local EPS demand significant reactive power contribution from PV-DGS as shown in Figs. 9(f) and 9(g) [compared to Figs. 9(b) and (d)].

In the 3rd and final case, discretized form of the proposed control law (6) was implemented in the DSP to study the efficacy of the proposed scheme and a series of experiments were performed again with same conditions as before. The gain of the controller is set at  $K_G = 0.7$  to reduce the sensitivity of control to other practical noise sources including imbalance on the bus and harmonics. Repeated experiments revealed that the proposed control law helps to suppress the electromechanical oscillations much more effectively, as shown in Fig. 9(h). Further, the rise in reactive power demand is momentary, just to assist with the damping of oscillations. The behavior of current injected by PV-DGS during the disturbance is shown in Fig. 9(i).

## VII. CONCLUSION

It is apparent that the future power systems would be operating under highly deregulated regime, with high penetration of the distributed renewable energy sources tied to the grid through a cluster of inverters. With the help of a novel scheme used in the context of a PV-DGS system, this paper has demonstrated how these numerous distributed generation interfaces can be used as ancillary support systems for enhancing the dynamic stability of the system. The salient features of the proposed scheme are summarized as follows:

- 1) The PV-DGS inverter can be used to enhance the dynamic stability of a weak local area power system by damping out the electromechanical oscillations thereby relieving the system from severe stresses.
- 2) It is capable of enhancing the penetration level of inverter based distributed energy sources
- 3) The proposed control law can be incorporated in the PV-DGS system without extensive modification in the power circuit or use of additional communication.

- 4) Locally acquired feedback signals are sufficient for implementing the proposed control scheme.
- 5) The MPPT or power optimization of PV-DGS remains unaffected during the assigned ancillary function.

The performance of the proposed control law has also been compared with the conventional schemes based on voltage regulation methods and is found to be more effective.

## REFERENCES

- [1] M. Bouzguenda and S. Rahman, "Value analysis of intermittent generation sources from the system operations perspective," *IEEE Trans. Energy Convers.*, vol. 8, no. 3, pp. 484–490, Sep. 1993.
- [2] A. Rueda-Media and A. Padilha-Feltrin, "Distributed generators as providers of reactive power support-A market approach," *IEEE Trans. Power Syst.*, vol. 28, no. 1, pp. 490–502, Feb. 2013.
- [3] *IEEE Standard for Interconnecting Distributed Resources With Electric Power Systems*, IEEE 1547, 2003.
- [4] J. Rueda, W. Guaman, J. Cepeda, I. Erlich, and A. Vargas, "Hybrid approach for power system operational planning with smart grid and small-signal stability enhancement considerations," *IEEE Trans. Smart Grid*, vol. 4, no. 1, pp. 530–539, Mar. 2013.
- [5] M. Noroozian, M. Ghandhari, G. Andersson, J. Gronquist, and I. Hiskens, "A robust control strategy for shunt and series reactive compensators to damp electromechanical oscillations," *IEEE Trans. Power Del.*, vol. 16, no. 4, pp. 812–817, Oct. 2001.
- [6] X. Xiaorong, C. Wenjin, T. Yiliang, and H. Yingduo, "Simultaneously-tuned decentralized control of excitation and STATCOM for voltage regulation and stability enhancement in power systems," in *Power System Technology, Proc. PowerCon*, Dec. 2000, vol. 3, pp. 1431–1436.
- [7] G. Shahgholian, S. Eshtehardiha, H. Mahdavi-Nasab, and M. Yousefi, "A novel approach in automatic control based on the genetic algorithm in STATCOM for improvement power system transient stability," in *Proc. 4th IEEE Conf. Intell. Syst.*, Sep. 2008, vol. 1, pp. 14–19.
- [8] R. Mihalic and U. Gabrijel, "A structure-preserving energy function for a static series synchronous compensator," *IEEE Trans. Power Syst.*, vol. 19, no. 3, pp. 1501–1507, Aug. 2004.
- [9] J. Kim, S. Cho, and H. Shin, "Advanced power distribution system configuration for smart grid," *IEEE Trans. Smart Grid*, vol. 4, no. 1, pp. 353–358, Mar. 2013.
- [10] S. Eftekharijrad, V. Vittal, G. Heydt, B. Keel, and J. Loehr, "Impact of increased penetration of photovoltaic generation on power systems," *IEEE Trans. Power Syst.*, vol. 28, no. 2, pp. 893–901, May 2013.
- [11] W. Du, H. Wang, and R. Dunn, "Power system small-signal oscillation stability as affected by large-scale PV penetration," in *Proc. Sustain. Power Gener. Supply Conf.*, Nanjing, China, Apr. 2009, pp. 1–6.
- [12] Y. Tan and D. Kirschen, "Impact on the power system of a large penetration of photovoltaic generation," in *Proc. Power Eng. Soc. Gen. Meet.*, Tampa, FL, USA, Jun. 2007, pp. 1–8.
- [13] A. Yazdani and P. Dash, "A Control methodology and characterization of dynamics for a photovoltaic (PV) system interfaced with a distribution network," *IEEE Trans. Power Del.*, vol. 24, no. 3, pp. 1538–1551, Jul. 2009.
- [14] A. Canova, L. Giaccone, F. Spertino, and M. Tartaglia, "Electrical impact of photovoltaic plant in distributed network," *IEEE Trans. Ind. Appl.*, vol. 45, no. 1, pp. 341–347, Feb. 2009.
- [15] P. McNutt, J. Hambrick, and M. Keese, "Effects of photovoltaics on the distribution system voltage regulation," in *Proc. 34th IEEE Photovoltaic Specialist Conf. (PVSC)*, Philadelphia, PA, USA, Jun. 2009, pp. 1914–1974.
- [16] Y. Liu, J. Bebic, B. Kroposki, J. De Bedout, and W. Ren, "Distribution system voltage performance analysis for high-penetration PV," in *Proc. IEEE Energy 2030 Conf.*, Atlanta, GA, USA, Nov. 2008, pp. 1–8.
- [17] S. Phuttapatimok, A. Sangswang, M. Seapan, D. Chenvidhya, and K. Kirtikara, "Evaluation of fault contribution in the presence of PV grid connected systems," in *Proc. 33rd IEEE Photovoltaic Specialist Conf.*, San Diego, CA, USA, May 2008, pp. 1–5.
- [18] K. Sedghisigarchi and A. Feliachi, "Dynamic and transient analysis of power distribution systems with fuel cells-Part II: Control and stability enhancement," *IEEE Trans. Energy Convers.*, vol. 19, no. 2, pp. 429–434, Jun. 2004.
- [19] H. Qi, X. Wang, L. Tolbert, F. Li, F. Peng, P. Ning, and M. Amin, "A resilient real-time system design for a secure and reconfigurable power grid," *IEEE Trans. Smart Grid*, vol. 2, no. 4, pp. 770–781, Dec. 2011.
- [20] N. Hingorani, *Understanding FACTS: Concept and Technology of Flexible AC Transmission System*. Delhi, India: IEEE Press, 2001.
- [21] X. Xie, J. Li, J. Xiao, and Y. Han, "Inter-area damping control of STATCOM using wide-area measurements," in *Proc. IEEE Electric Utility Deregulation, Restructuring, Power Technol. (DRPT)*, Apr. 2004, vol. 1, pp. 222–227.
- [22] A. Chakraborty, J. Chow, and A. Salazar, "A measurement-based framework for dynamic equivalencing of large power systems using wide-area phasor measurements," *IEEE Trans. Smart Grid*, vol. 2, no. 1, pp. 68–81, Mar. 2011.
- [23] M. Jin, Z. Pu, F. Hong-jun, B. Bo, and D. Zhao-yang, "Application of phasor measurement unit on locating disturbance source for low-frequency oscillation," *IEEE Trans. Smart Grid*, vol. 1, no. 3, pp. 340–346, Dec. 2010.
- [24] S. Qu and C. Chen, "Low frequency oscillations damping by STATCOM with a fuzzy supplementary controller," in *Proc. IEEE Power System Technol.*, Oct. 2002, vol. 1, pp. 60–70.
- [25] M. Pai, *Energy Function Analysis for Power System Stability*. London, U.K.: Kluwer Academic, 1989.
- [26] V. Azbe and R. Mihalic, "The control strategy for an IPFC based on the energy function," *IEEE Trans. Power Syst.*, vol. 23, no. 4, pp. 1662–1669, Nov. 2008.
- [27] N. Ainsworth and S. Grijalva, "A structure-preserving model and sufficient condition for frequency synchronization of lossless droop inverter-based AC networks," *IEEE Trans. Power Syst.*, to be published.
- [28] T. Odun-Ayo and M. Crow, "Structure-preserved power system transient stability using stochastic energy functions," *IEEE Trans. Power Syst.*, vol. 27, no. 3, pp. 1450–1458, Aug. 2012.
- [29] D. Zhou, Z. Zhao, M. Eltawil, and L. Yuan, "Design and control of a three-phase grid-connected photovoltaic system with developed maximum power point tracking," in *Proc. Appl. Power Electron. Conf. (APEC)*, Austin, TX, USA, Feb. 2008, pp. 973–979.
- [30] K. Moudgalya, *Digital Control*. Wiltshire, U.K.: Wiley, 2007.
- [31] P. Kundur, *Power System Stability and Control*. Delhi, India: Tata McGraw-Hill Ed., 2008.
- [32] C. Li, Z. Wang, X. Ma, and L. Xiu, "Physical experiments on a 10 Kvar STATCOM model," in *Proc. IEEE Power Eng. Soc. Winter Meet.*, Feb. 1999, vol. 2, pp. 1184–1189.
- [33] R. Wandhare and V. Agarwal, "A modified control strategy for centralized PV—Grid systems for assisting dynamic stability to overcome penetration issues," in *Proc. 38th IEEE Photovoltaic Specialist Conf.*, Austin, TX, USA, Jun. 2012, pp. 1540–1544.



**Rupesh G. Wandhare** (S'11) received the B.E. degree from Nagpur University, India, in 2005. He is currently pursuing the M.Tech. and Ph.D. dual degree in the Department of Electrical Engineering, IIT, Bombay, India.

He worked for Indorama Synthetics Ltd, Nagpur, India, as a Project Engineer from June 2005 to June 2007 for the planning and commissioning of electric equipment, drives, electric panels, etc., and in Thermal Power Station, CSTPS, Chandrapur, India, from June 2007 to July 2008 for the maintenance of

HT/LT motors, electric systems, etc. His areas of research include designing of power conditioning units, control and protection design for the distributed generation system, and microgrid. He is also exploring new power converter topologies and their controls for renewable energy conditioning.

**Vivek Agarwal**, photograph and biography not available at the time of publication.