



ارائه شده توسط:

سایت ترجمه فا

مرجع جدیدترین مقالات ترجمه شده

از نشریات معتبر

## Temperature Dependence and Effect on Surface Roughness in Abrasive Flow Machining

G. Z. Song<sup>a</sup>, Y. Z. Li<sup>b</sup> and G. Ya<sup>c</sup>

College of Mechanical Engineering, Taiyuan University of Technology,  
Taiyuan, 030024, Shanxi, China

<sup>a</sup>gzh\_s@163.com, <sup>b</sup>liy@tyut.edu.cn, <sup>c</sup>yagang1@163.com

**Keywords:** Abrasive flow machining; Medium; Temperature; Surface roughness; Finishing

**Abstract.** In this paper we discuss the temperature dependence and its effect on surface roughness. In abrasive flow machining (AFM) process the temperature of media rises drastically due to procedure of being sheared. To examine the effect of media temperature on surface roughness, an experiment system with the functions of controlling, measuring and recording temperature is set up. The variable trend of media temperature is revealed during AFM. Experiments are performed at different temperatures. Experimental results show that the media at high temperature results in less improvement in surface roughness. Therefore the media can have good machining performance in the first few cycles and the media temperature rise rapidly. Finally we conclude that the best workable temperature should be below 25 °C during the AFM.

### Introduction

Abrasive flow machining (AFM) is a non-traditional finishing process, which possesses excellent capabilities for finishing complicated surface and inaccessible regions of a workpiece [1]. In AFM, an abrasive-laden polymeric medium is extruded under pressure through the surface to be machined or the restrictive passage formed by the workpiece and fixture assembly. The more restrictive the passage is, the faster media flow speed is. In this case, the stronger AFM action becomes. On the other hand, the media is sheared seriously when it is extruded through the narrow passage. The temperature of media rises drastically and the viscosity of media decreases at the same time. The action of AFM gets weak. The exact mechanism of AFM has been understood due to the complications of effect factors. Hence, it is of great practical and theoretical interest to study temperature rise during the AFM process.

The theoretical and experimental determination of thermal properties of medium is carried out by Fletcher and Fioravanti [2]. Davies and Fletcher [3] experimentally found that viscosity of medium is significantly affected by temperature. Viscosity of highly viscous medium reduces drastically even with a small increase in temperature (2-10°C). R.K. Jain and V.K. Jain proposed a simple model analysis to understand thermal phenomenon of AFM and thereby to predict temperature change during the process [4]. Moreover, the rheological properties have been studied by some reports [5,6]. The experiments show that the viscosity of medium is seriously influenced by temperature. In this paper, the real-time temperature change is measured and recorded by a control and measure system with computer. Experiments are performed at setting high temperatures. The effect of temperature on surface roughness is studied directly.

This paper is organized as following. Next section mainly introduces the experiment system of abrasive flow machining. In the following section, the experiment procedure is discussed in detail. Then analysis and discussion are given. Finally conclusion is made.

### Experiment System

The experiment system developed is shown as Fig. 1. The setup includes experimental mechanical structure, control and measure system, workpiece, fixture, and medium. This section is divided into five parts.

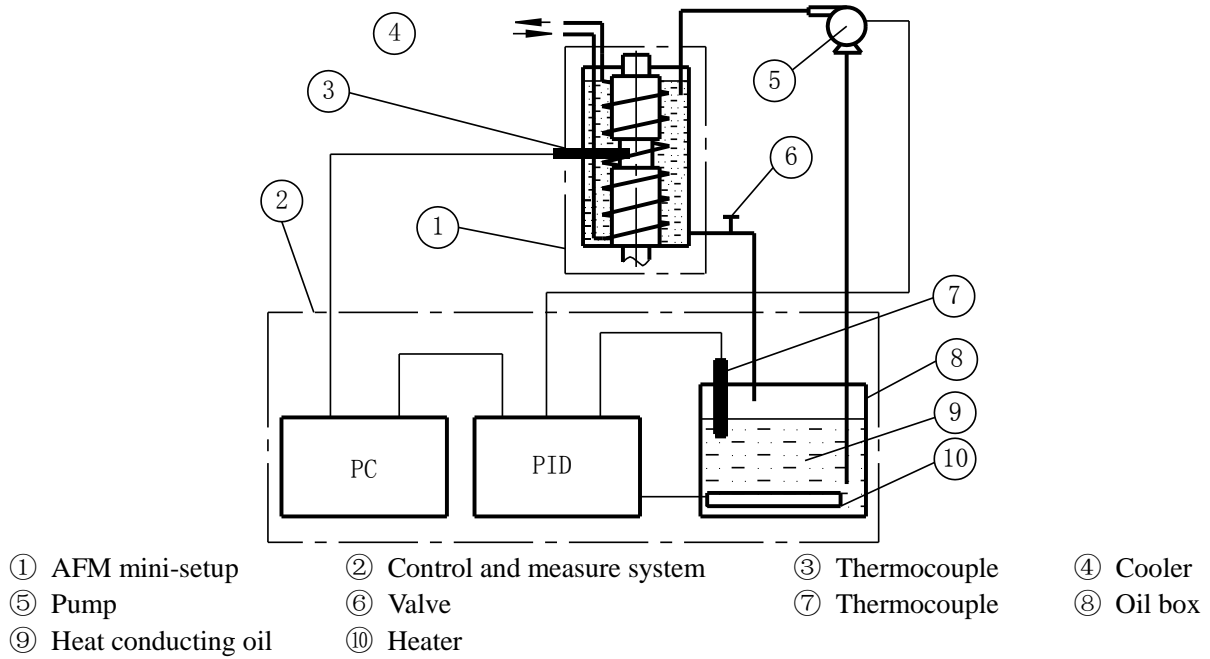

Fig. 1 Schematic diagram of experiment system

**Experimental Mechanical Structure.** To allow setting high temperatures, a set of experimental mechanical structure is designed and manufactured, see Fig. 2. It includes two vertically opposite media mini-cylinders (inside diameter 63mm), an out barrel and water pipe for cooling. The fixture and workpiece are clamped between the upper and lower cylinders. The lower cylinder is fixed onto the bottom of outside barrel by screws. Heat conducting oil is circularly pumped into the barrel after it is heated in the oil box (see ⑧ of Fig.1). The MB9215 AFM machine developed by Taiyuan University of Technology is used for driver which drives up and down the pistons of mini-cylinders. The relation between hydraulic pressure ( $p_{\text{machine}}$ ) of MB9215 and media pressure ( $p_{\text{media}}$ ) in cylinder is:

$$p_{\text{media}} = \left(\frac{180}{63}\right)^2 p_{\text{machine}} \approx 8.16 p_{\text{machine}} \quad (1)$$

**Workpiece.** Workpieces used for experiments are made into two halves assembled shown as Fig. 3. It is easy to be measured. The restrictive passage formed is a slit with rectangular section ( $22 \times 1$ ). The surface forming passage is produced by milling with surface roughness of  $4.8 \mu\text{m Ra}$ . There is a thermocouple hole on the side of workpiece. The end of hole is very near to the passage surface.

**Fixture.** In this study, the fixture is designed as shown Fig. 4. There is also a hole in fixture corresponding of workpiece.

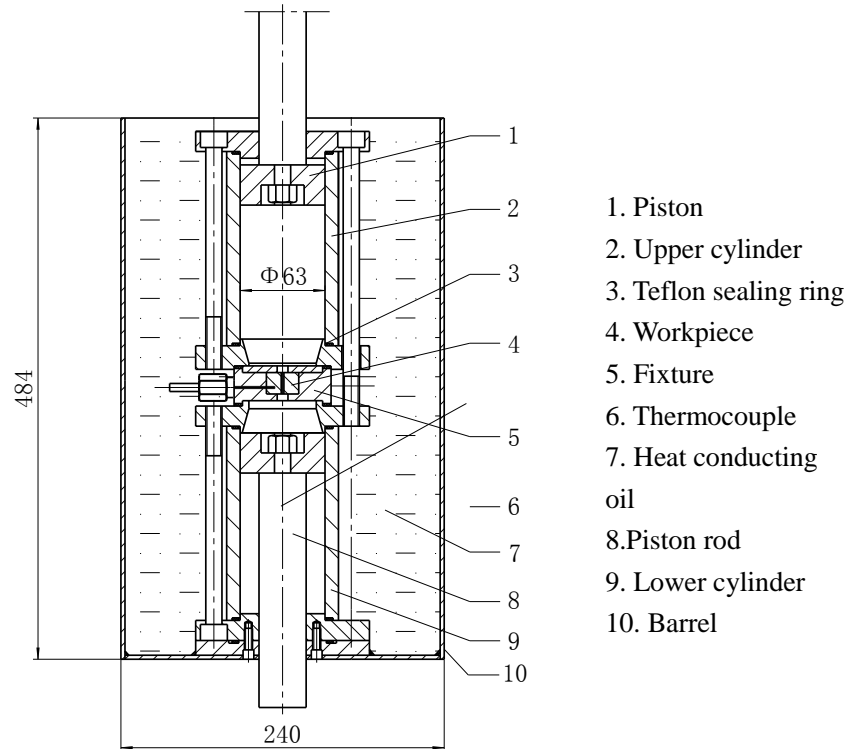

Fig. 2 Assembly drawing of AFM set-up

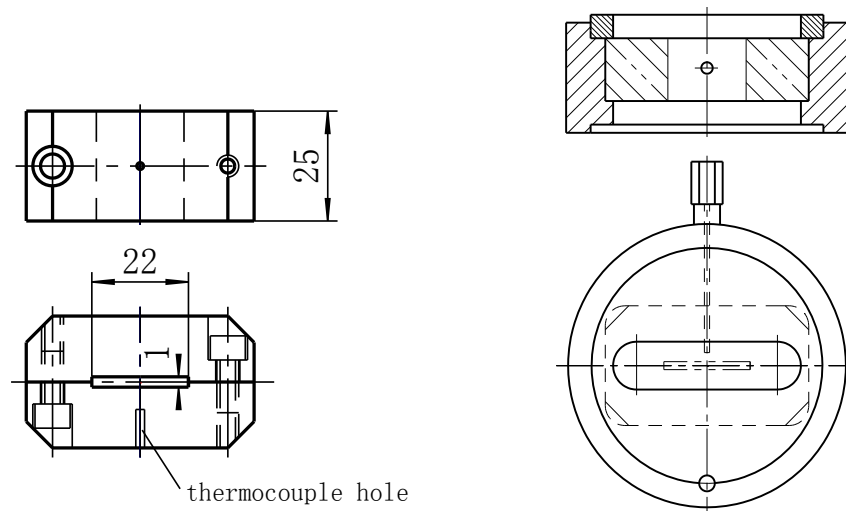

Fig. 3 Workpiece

Fig. 4 Fixture

**Control and Measure System.** A control and measure system is developed for two purposes. One is for real-time measuring and recording the temperature change during AFM. Another is for setting high temperatures required by experiments. The system includes PID intelligent controller, thermocouple, heat-conducting silicon resin, computer, program for collecting and dealing datum, heater, cooler, heat conducting oil, and a pump circle system. The use of heat-conducting silicon resin is for measurement of temperature exact as possible. The hole of workpiece needs to be filled by the heat-conducting silicon resin before the thermocouple is inserted into the hole, thus the gap between the end of thermocouple and the hole is eliminated to ensure the accuracy of measurement. The heat conducting oil in the oil box acts as a medium to set high temperatures in AFM experiment. The oil need to be heated to a setting temperature by heaters installed in the oil box and the setting value becomes stable by PID controlling. In experiment processing, the heat conducting oil is pumped into the out barrel of the experimental set-up circularly by a pump. In order to make the

setting temperature stable and to avoid effect of increasing temperature during the AFM process, there is a cooler in the barrel in which cooling water flows. The measurement of temperature is real-time collected and recorded by the computer with data sampling cycle of 200 ms and data recording cycle of 1000 ms, then the measurement values are shown as a curve with interpolation of cubic spline and drawing period of 1000 ms.

**Medium.** The medium acts as a “deformable grinding tool”. It is the key of AFM. Its work temperature is investigated in this study. The medium used for AFM experiments, which is developed by ourselves, is a semisolid mixture composed of silicon rubber, additive agents and silicon carbon (SiC) with mesh size 80. The abrasive concentration is 60% by weight. This medium has good processing ability and has been applied to many industrial productions.

### Experiment Procedure

To study effect of medium temperature on surface roughness in AFM, first the temperature change of medium must be understood during AFM processing, so that the range of experiment temperature is determined and the temperature interval is selected. Then the AFM experiments are performed at setting temperatures.

**Change of Temperature during AFM.** The experiment is performed for one workpiece at room temperature (20 °C). In this procedure, the control and measure system only is used to measure and record temperature during the AFM process not to control it. Other process parameters are as follows:

No. of cycle: 10. (One cycle spends 5 seconds)

Hydraulic pressure: 6MPa. (The pressure of medium equals 49MPa)

The medium flow speed computed is 217.53m/min.

Fig. 5 shows the result of this experiment. From the figure, it is obvious that the temperature of medium rises drastically at the first several cycles and up to the highest value (91 °C) after 4 cycles but with a degressive increment. Then the temperature of medium descends slowly. It begins to go down at a rapid speed after 10 cycles set is over. The phenomenon indicates that the cutting energy of medium with a certain cutting ability transfers into heat energy during AFM process, thereby the temperature of medium rises and the cutting ability weaken. After 4 cycles, the cutting ability becomes very weak, so that the heat produced is smaller than the heat lost. Although the result reported in [4] provides some information, the temperature curve based on a few discrete measurements shows only partially the temperature change during AFM process. Fig.5 first fully reveals the variable trend of temperature and reflects the significant effect of temperature on the processing property of AFM.

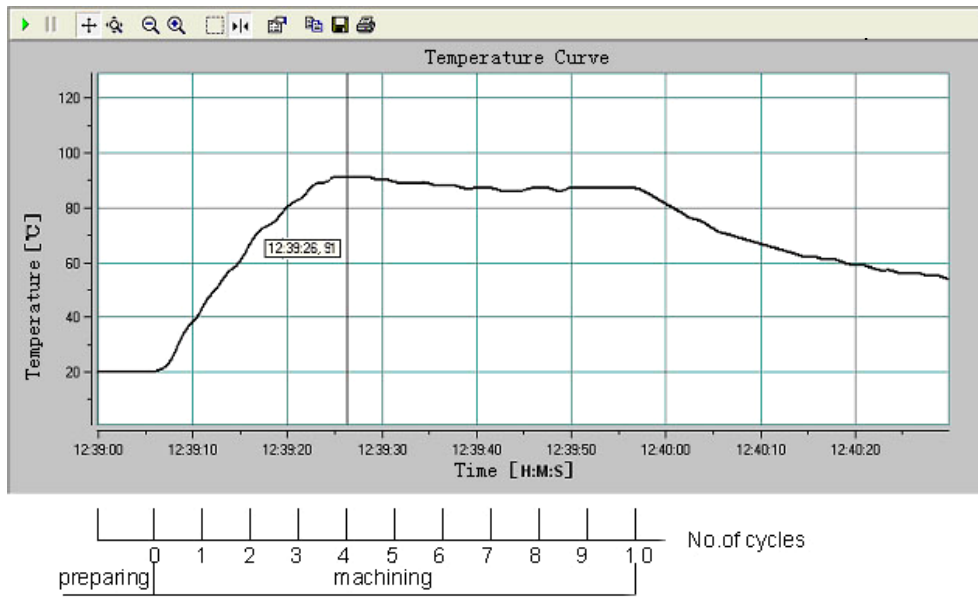

Fig. 5 Temperature during AFM processing

**AFM Processing at Different Temperatures.** According to the variable trend of temperature understood, 90°C is determined as the highest experimental temperature to be set and 10°C as an interval. The AFM process is repeated for 20°C, 30°C, 40°C, 50°C, 60°C, 70°C, 80°C and 90°C using eight workpieces. The number of cycles is 6 times. Other processing parameters are the same as above mentioned. Set a temperature value before the heater starts. The pump circle system begins to pump the heat conducting oil from the oil box to the outside barrel of mini-cylinders. When the oil level in the barrel has gotten to a high at which the mini-cylinders immerse in the oil, the oil not only is pumped into the barrel but also flows back the oil box through a valve to keep the oil level constant. Thus, the workpiece, mini-cylinders and inner medium are in an environment which is rising in temperature. The AFM process isn't began until the measured value of temperature is equal to the set value and keeps constant for half hour. The cooler begins to work in order to balance the increasing temperature during the process and insure the temperature stable during the machining. After the machining is over, the workpieces are taken out, opened and cleaned before any measurement is taken. The instrument used to measure surface roughness value, Ra, of the finished workpiece, is the Perthometer-M2.

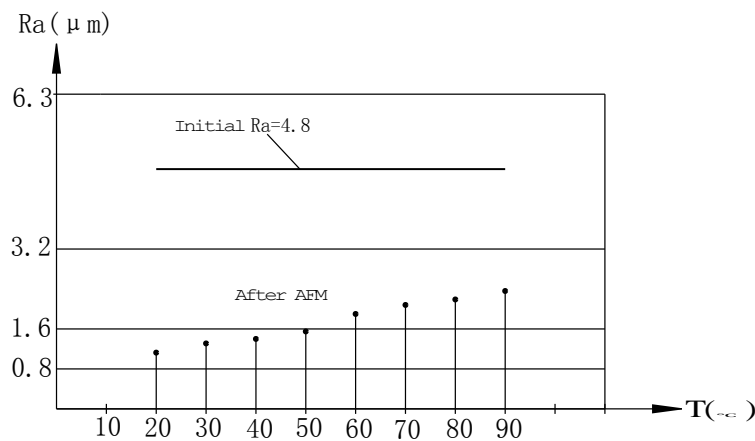

Fig. 6 Effect of temperature on surface roughness

### Analysis and Discussion

Fig. 6 shows the surface roughness of workpieces machined by AFM. For the workpiece with Ra 4.8  $\mu\text{m}$  initial surface roughness, the surface roughness may decrease two grades after AFM at below 40°C and one grade at above 50°C. The machining action of media decreases with increasing in temperature.

### Conclusions

This research first reveals the variable trend of temperature during the AFM processing. The surface roughness of surfaces finished by AFM at different temperatures is studied. The following conclusions have been derived from the above study:

(1) Effect of temperature on surface roughness of the surfaces machined by AFM is serious. The machining action of AFM is strong at low temperature and weak at high temperature. The efficient machining should be below 40°C, the most efficient machining should be below 25°C.

(2) Without control of temperature, the machining action produces mainly from first a few cycles. The more cycles aren't useful to improvement the surface roughness.

(3) In order to realize a stable and efficiency machining, the temperature must be controlled during the AFM process. The roughness is good with increasing number of cycles after the temperature is controlled at low.

### References

- [1] L. J. Rhoades: Abrasive flow machining, *Manuf. Eng. Nov.* (1988), p. 75–78
- [2] A. J. Fletcher, A. Fioravanti: Polishing and honing process: an investigation of the thermal properties of mixtures of polyborosiloxane and silicon carbide abrasive, *Proceedings of the Institution of Mechanical Engineers*, Vol. 210(1996), p. 256-265
- [3] P. J. Davies, A. J. Fletcher: The assessment of the rheological characteristics of various polyborosiloxane/grit mixtures as utilized in the abrasive flow machining process, *Proceedings of the Institution of Mechanical Engineers*, Vol. 209(1995), p.409-418
- [4] R. K. Jain, V. K. Jain: Specific energy and temperature determination in abrasive flow machining process, *International Journal of Machine Tools & Manufacture*, Vol. 41(2001), p.1689-1704
- [5] R. E. Williams, K. P. Rajurkar: Stochastic modeling and analysis of abrasive flow machining, *Transaction of ASME. Journal of Engineering for Industry*, Vol. 114(1992), p.74-81
- [6] A. J. Fletcher, A. Fioravanti: Polishing and honing process: an investigation of the thermal properties of mixtures of polyborosiloxane and silicon carbide abrasive, *Proceedings of the Institution of Mechanical Engineers*, Vol. 210(1996), p.256-265

**Surface Finishing Technology and Surface Engineering**

10.4028/www.scientific.net/AMR.53-54

**Temperature Dependence and Effect on Surface Roughness in Abrasive Flow Machining**

10.4028/www.scientific.net/AMR.53-54.375





این مقاله، از سری مقالات ترجمه شده رایگان سایت ترجمه فا میباشد که با فرمت PDF در اختیار شما عزیزان قرار گرفته است. در صورت تمایل میتوانید با کلیک بر روی دکمه های زیر از سایر مقالات نیز استفاده نمایید:

لیست مقالات ترجمه شده ✓

لیست مقالات ترجمه شده رایگان ✓

لیست جدیدترین مقالات انگلیسی ISI ✓

سایت ترجمه فا ؛ مرجع جدیدترین مقالات ترجمه شده از نشریات معتبر خارجی