



Standard Test Methods for Laboratory Miniature Vane Shear Test for Saturated Fine-Grained Clayey Soil¹

This standard is issued under the fixed designation D4648/D4648M; the number immediately following the designation indicates the year of original adoption or, in the case of revision, the year of last revision. A number in parentheses indicates the year of last reappraisal. A superscript epsilon (ϵ) indicates an editorial change since the last revision or reappraisal.

1. Scope*

1.1 These test methods cover the miniature vane test in very soft to stiff saturated fine-grained clayey soils ($\phi = 0$). Knowledge of the nature of the soil in which each vane test is to be made is necessary for assessment of the applicability and interpretation of the test results.

NOTE 1—It is recommended that the miniature vane test be conducted in fine-grained, predominately clay soils with an undrained shear strength less than 1.0 tsf [100 kPa]. Vane failure conditions in higher strength clay and predominantly silty soils may deviate from the assumed cylindrical failure surface, thereby causing error in the measured strength.

1.2 These test methods include the use of both conventional calibrated torque spring units (Method A) and electrical torque transducer units (Method B) with a motorized miniature vane shear device.

1.3 Laboratory vane is an ideal tool to investigate strength anisotropy in the vertical and horizontal directions, if suitable samples (specimens) are available.

1.4 All measured and calculated values shall conform to the guidelines for significant digits and rounding established in Practice D6026.

1.5 The values stated in either SI units or inch-pound units are to be regarded separately as standard. The values stated in each system may not be exact equivalents; therefore, each system shall be used independently of the other. Combining values from the two systems may result in non-conformance with the standard.

1.5.1 The gravitational system of inch-pound units is used when dealing with inch-pound units. In this system, the pound (lbf) represents a unit of force (weight), while the unit for mass is slugs. The rationalized slug unit is not given, unless dynamic ($F = ma$) calculations are involved.

1.6 *This standard does not purport to address all of the safety concerns, if any, associated with its use. It is the responsibility of the user of this standard to establish appropriate*

appropriate safety and health practices and determine the applicability of regulatory limitations prior to use.

2. Referenced Documents

2.1 ASTM Standards:²

- D653 Terminology Relating to Soil, Rock, and Contained Fluids
- D1587 Practice for Thin-Walled Tube Sampling of Fine-Grained Soils for Geotechnical Purposes
- D2216 Test Methods for Laboratory Determination of Water (Moisture) Content of Soil and Rock by Mass
- D2488 Practice for Description and Identification of Soils (Visual-Manual Procedure)
- D2573 Test Method for Field Vane Shear Test in Saturated Fine-Grained Soils
- D3740 Practice for Minimum Requirements for Agencies Engaged in Testing and/or Inspection of Soil and Rock as Used in Engineering Design and Construction
- D4220 Practices for Preserving and Transporting Soil Samples
- D6026 Practice for Using Significant Digits in Geotechnical Data

3. Terminology

3.1 Definitions:

3.1.1 For common definitions of terms in this standard, refer to Terminology D653.

3.2 Definitions of Terms Specific to This Standard:

3.2.1 *torque*—the product of the magnitude of a force and the perpendicular distance of the line of action of the force from a specified axis of rotation.

3.2.2 *torque spring*—an elastic spring that can be calibrated to provide a measure of torque that is proportional to the rotation (about a central longitudinal axis) of one end of the spring relative to a fixed condition at the opposite end of the spring.

¹ This test method is under the jurisdiction of ASTM Committee D18 on Soil and Rock and is the direct responsibility of Subcommittee D18.05 on Strength and Compressibility of Soils.

Current edition approved Jan. 1, 2016. Published January 2016. Originally approved in 1987. Last previous edition approved in 2013 as D4648/D4648M – 13. DOI: 10.1520/D4648_D4648M-16.

² For referenced ASTM standards, visit the ASTM website, www.astm.org, or contact ASTM Customer Service at service@astm.org. For *Annual Book of ASTM Standards* volume information, refer to the standard's Document Summary page on the ASTM website.

*A Summary of Changes section appears at the end of this standard

3.2.3 *torque transducer*—an electronic measuring device that can be calibrated to provide a measure of torque.

4. Summary of Test Method

4.1 The miniature vane shear test consists of inserting a four-bladed vane in the end of an intact tube sample or remolded sample and rotating it at a constant rate to determine the torque required to cause a cylindrical surface to be sheared by the vane. This torque is then converted to a unit shearing resistance of the cylindrical surface area. The torque is measured by a calibrated torque spring or torque transducer that is attached directly to the vane.

5. Significance and Use

5.1 The miniature vane shear test may be used to obtain estimates of the undrained shear strength of fine-grained soils. The test provides a rapid determination of the shear strength on undisturbed, or remolded or reconstituted soils.

NOTE 2—Notwithstanding the statements on precision and bias contained in this test method: The precision of this test method is dependent on the competence of the personnel performing it and the suitability of the equipment and facilities used. Agencies that meet the criteria of Practice D3740 are generally considered capable of competent and objective testing. Users of this test method are cautioned that compliance with Practice D3740 does not in itself ensure reliable testing. Reliable testing depends on several factors; Practice D3740 provides a means for evaluating some of those factors.

6. Interferences

6.1 *Vane Disturbance*—The remolded zone around a vane blade resulting from insertion is generally assumed to be small and have little or no effect on the stress-strain properties of the sediment being tested. In reality, the volume of soil disturbed by the insertion of the vane blade into the assumed cylindrical volume of soil being tested may be significant. It is recom-

mended that the vane displace no more than 15% of the soil being tested as defined by the vane area ratio presented in Fig. 1.

7. Apparatus

7.1 *Vane Blade*—The vane assembly shall consist of four rectangular bladed vanes, as illustrated in Fig. 2. It is recommended that the height of the vane be twice the diameter (2:1), although vanes with a height equal to the diameter (1:1) also may be used (see Note 3). Vane blade diameter (*D*) may vary from 0.5 to 1.0 in. [12.7 to 25.4 mm].

7.2 *Vane Device*—The vane device should be motorized and, in the case of a torque spring device, shall rotate the torque spring at a constant rate of 60 to 90°/min [1.0 to 1.6 rad/min]. A vane device which applies the torque directly through a stiff shaft using an electrical transducer to measure torque shall rotate the vane at a constant rate that ranges from 20 to 30°/min [0.35 to 0.52 rad/min]. The vane/spring rotation device shall have an indicator or recording system that displays/records deflection (torque) of the calibrated spring or electrical transducer and, where possible, vane blade rotation.

7.3 *Torque Measuring Device*—The torque measuring device shall be a conventional torque spring, electrical torque transducer, or any other measuring device capable of the accuracy prescribed herein and may be part of the vane device. The torque measuring device shall be capable of measuring the torque to at least three significant digits.

NOTE 3—Since many clays are anisotropic with respect to strength, the relative importance of horizontal, as distinct from vertical, shearing surfaces can influence the test results. For this reason it is important that the recommended ratio of height to diameter be respected unless the intent is to vary the ratio in order to determine the horizontal and vertical strengths separately. For more detailed discussion on effects of height to

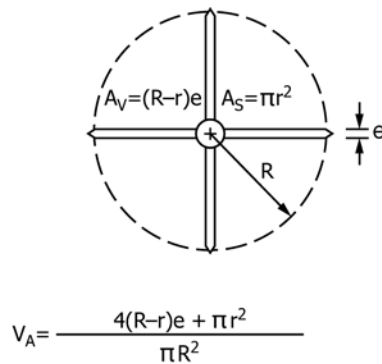

Where : V_A = Vane Area Ratio
 R = Radius of Failure Cylinder (in or mm)
 r = Radius of Vane Shaft (in or mm)
 e = Vane Blade Thickness (in or mm)

VANE TYPE	BLADE DIA. in (mm)	SHAFT DIA. in (mm)	BLADE THICKNESS in (mm)	AREA RATIO (%)
Miniature	0.50 (12.7)	0.1275 (3.5)	0.019 (0.05)	13.7

FIG. 1 Vane Area Ratio for ASTM Vanes

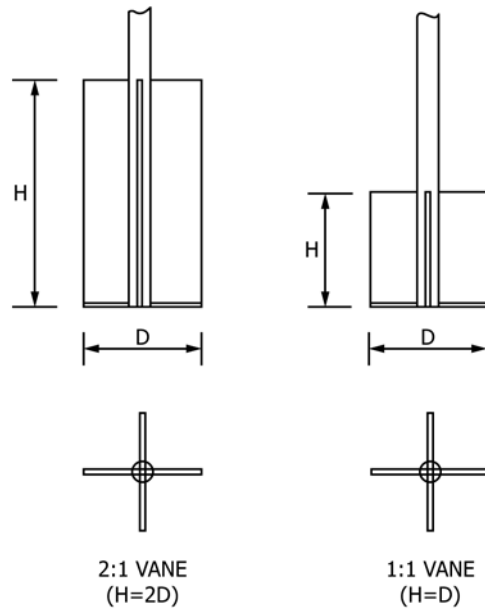

FIG. 2 Miniature Vane Blade Geometry

diameter ratio as well as vane shape, refer to Refs. (1) and (2).³

8. Preparation and Testing of Samples

8.1 *Specimen Size*—Specimens should have a diameter sufficient to allow clearance of at least two blade diameters between all points on the circumference of the shearing surface and the outer edge of the sample.

8.2 *Intact Vane Strength*—Prepare intact specimens from large intact samples secured in accordance with Practice D1587, and handle and transport in accordance with the practices for Group C and D Samples in Practices D4220. Tests may be run in the sampling tube, eliminating the need for extrusion. Handle specimens carefully to prevent disturbance or loss of water (moisture) content. Trim flat the end of the sample where the vane will be inserted. The sample shall be perpendicular to the wall of the tube.

8.3 *Remolded Vane Strength*—Conduct remolded miniature vane strength tests on failed specimens similar to remolded field vane tests (Test Method D2573) by rotating the vane rapidly through a minimum of five to ten revolutions.

NOTE 4—Remolded shear strength measurements are conventionally obtained by conducting strength tests on specimens encased in a thin rubber membrane, to prevent change in water content, and remolded by hand (hand remolding). Field vane remolded strength has however been obtained by rotating the vane rapidly through a minimum of five to ten complete revolutions and conducting a vane test within 1 min of the remolding process (machine remolding). A machine remolded test yields a vane strength value that is considered more a residual strength. The machine remolded strength is typically higher than the hand remolded strength and, as a consequence, produces lower sensitivities. In many sensitive clayey soils, residual strengths may be obtained within one to two revolutions or less. If such soils are being tested, it is recommended that several remolded strengths be obtained using the standard five to ten revolutions for verification. If no major remolded strength differences are

³ The boldface numbers in parentheses refer to the list of references at the end of this standard.

noted, remolded strengths may be obtained at less than the recommended five to ten revolutions.

NOTE 5—In cases where electrical torque transducers with wires for signal transmission are utilized, the remolded miniature vane strength may be obtained by rotating the vane one complete revolution in one direction and then again in the opposite direction a number of times to produce the desired five to ten complete revolutions.

9. Preparation of Apparatus

9.1 *Vane Blade Damage*—Carefully check each vane prior to each use for bent shafts and blades and imperfections that could alter the vane failure surface from the assumed cylindrical surface.

10. Calibration

10.1 Conduct periodically calibration of the spring units (or torque transducers) to ensure proper operation of the miniature vane device and repeatability of the torque spring or transducers. Calibration is accomplished by the application of calibrated weights onto a calibrated wheel to produce a known torque (lever arm X weight). Secure the vane shear unit in such a way that the vane spring (torque unit) is in a horizontal position. Then insert the calibration wheel in place of the vane blade. The calibration wheel, calibration string, and calibration weights all shall hang free of any obstructions. Dimensions of the calibration wheel shall be noted; specifically the lever arm.

10.2 For each vane torque spring to be used, apply a series of calibration weights to the calibration wheel to develop a plot of spring deflection (in degrees) versus torque (in lbf-in. or [N·m]). Carefully fasten each calibration weight to the calibration string and allow to deflect the spring. Record the deflection of the spring (in degrees) and applied torque for each weight applied. The calibration wheel configuration, lever arm, weights, and resulting torque shown in Fig. 3 is recommended for consideration in the calibration procedure.

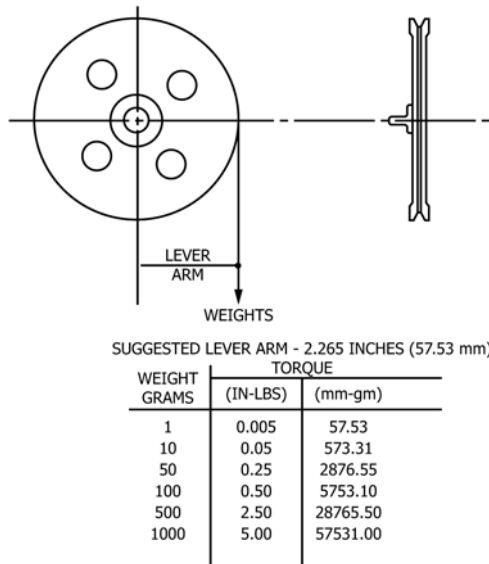

FIG. 3 Typical Calibration Wheel Configuration and Weight Selections

11. Application and Measurement of Vane Blade Torque

11.1 Apply the torque to the vane by a conventional torque spring (Fig. 4a) or an electrical torque transducer (Fig. 4b) that

is rotated with the vane/spring rotation device. The torque spring or transducer shall produce a repeatable linear relationship between spring deflection (degrees) or transducer output (mV) and torque applied.

NOTE 6—Since vane strength may be greatly influenced by the rate at which shear occurs, it is recommended that torque be applied using a motorized vane device. A hand crank manual device may be utilized, but is not recommended due to the potential variation in rate of shear.

NOTE 7—When the miniature vane test is conducted using a calibrated torque spring, the top of the spring unit is rotated at a constant rotation rate while the bottom of the spring most often remains stationary or nearly stationary until enough energy (torque) is built up in the spring. Just prior to or at failure, the bottom of the spring and vane begin to rotate (generally slowly) as failure begins. The torque applied by the spring soon overcomes the shearing resistance of the soil and the vane blade rotates rapidly to bring the soil to total failure. Thus, depending upon the stiffness of the calibrated torque spring, soil strength, and consistency, the rate of shear and possibly the shear strength may vary.

NOTE 8—It should be recognized that there is a fundamental difference in the failure modes between miniature vane tests made using a calibrated torque spring and an electrical transducer. An electrical torque transducer will produce a strain-controlled failure of the soil, whereas a calibrated torque spring will produce failure that varies somewhere between purely stress-controlled and strain-controlled conditions. Using an electrical torque transducer, the constant rate of rotation applied to the top of the torque transducer is transmitted directly to the vane blade. The resulting strain-controlled failure could result in a higher rate of shear than that produced using a calibrated torque spring.

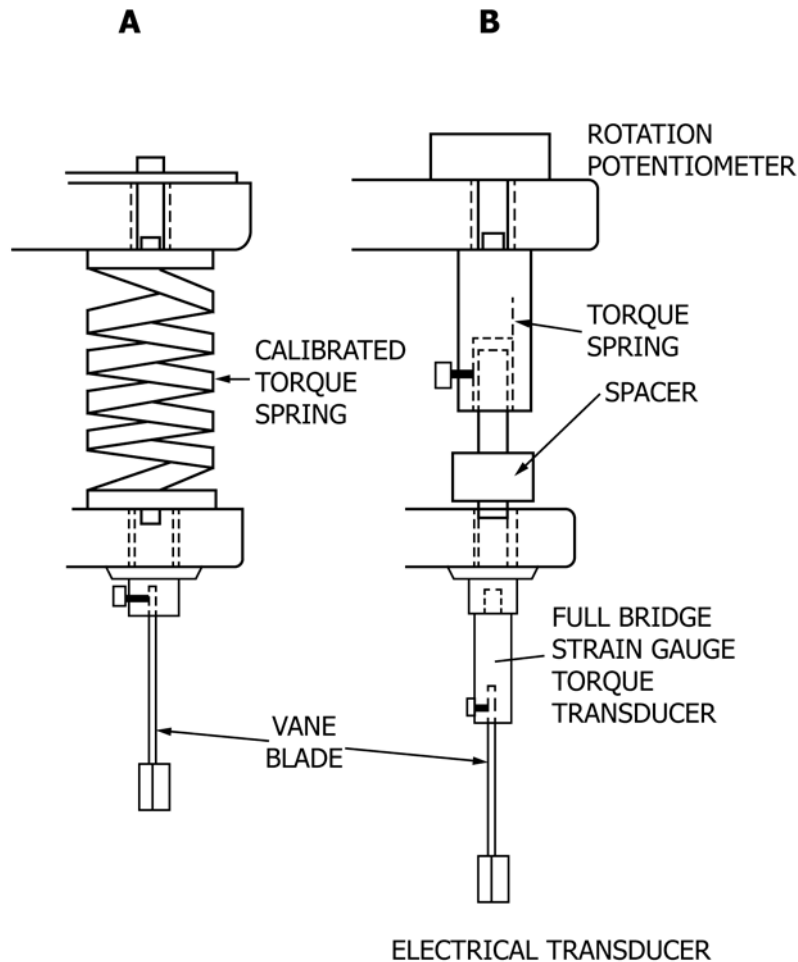

FIG. 4 Vane Torque Spring and Electrical Transducer Details Geometry

12. Vane Rotation and Shearing Rate

12.1 Apply torque to the vane/spring at a constant rate within the ranges identified in 7.2. Select the combination of torque spring or vane rotation rates to cause specimen to reach failure within 2 to 3 min (see Note 9).

NOTE 9—The rate of vane rotation has two major effects on the resulting measured vane shearing strength. The first is preventing drainage so that a truly undrained shear strength is measured. The second resembles a viscous effect: the faster a soil is sheared the higher is its measured strength. There are currently two approaches for determining the vane rotation and shearing rate. These approaches are (1) angular shear velocity approach, and (2) Blight's drainage approach. A more detailed discussion of these two approaches can be found in Refs. (3) and (4), respectively.

13. Miniature Vane Test Procedures

13.1 Fasten the vane shear unit, as well as the specimen container, securely to a table or frame to prevent movement during a test. Insert the vane in the sample to a minimum depth equal to twice the height of the vane blade to ensure that the top of the vane blade is embedded at least one vane blade height below the sample surface (see Note 10).

NOTE 10—If a very long shaped vane (12 in. [305 mm]) is employed to test within a sample, then the adhesion between the shaft and the soil must be evaluated. The adhesion is evaluated by inserting a shaft, without the vane, having the same dimensions as the actual vane shaft, into the soil to the level to be tested and noting the resulting torque versus rotation. The torque is subtracted from actual test results. To eliminate this correction, the actual torque shaft can be encased in a frictionless sleeve to prevent adhesion from occurring.

13.2 Take an initial reading. Hold the sample firmly to prevent rotation. Initiate mechanically rotation of the vane so as to rotate the top of the spring or transducer at a constant rate in accordance with 12.1. Record spring deflection or torque transducer readings at least every 5° of rotation until the spring deflection does not increase (which is considered failure) or until a maximum of 180° of rotation is obtained. During the rotation of the vane, hold the vane blade at a fixed elevation. Record the rotation rate, maximum torque and intermediate torque readings if required. Remove and clean the vane blade if necessary. Secure a representative sample of the specimen to determine the water content in accordance with Test Methods D2216. Inspect the soil for inclusions such as sand and gravel and cracking of the failure surface, which may influence test results. Record the findings.

13.3 Following the determination of the maximum torque, determine the remolded vane strength by rotating the vane rapidly through a minimum of five to ten revolutions; the determination of the remolded strength should be started immediately after completion of rapid rotation and in all cases within 1 min after the remolding process. Repeat the procedure in 13.1 and 13.2.

14. Calculation

14.1 Calculate the undrained shear strength in the following manner (see Note 11). The turning moment required to shear the soil is given as follows:

$$T = \tau \times K \quad (1)$$

where:

T = torque, lbf-ft [N·m],
 τ = undrained shear strength, lbf/ft² [Pa], and
 K = vane blade constant, ft³ [m³].

NOTE 11—The undrained shear strength (τ) determined in this laboratory procedure needs to be multiplied by a vane correction factor (μ) to give a field value of undrained shear strength, $(\tau)_{\text{field}} = \mu(\tau)_{\text{lab}}$. A more detailed discussion of the use of the vane correction factor is given in Refs. (5) and (6).

14.2 Assuming the distribution of the shear strength is uniform across the ends of the failure cylinder and around the perimeter, K is given as follows:

$$K = \frac{\pi D^2 H}{3456} \left[1 + \frac{D}{3H} \right] \text{ (Inch - Pound Units)} \quad (2)$$

$$K = \frac{\pi D^2 H}{2 \times 10^9} \left[1 + \frac{D}{3H} \right] \text{ [SI Units]} \quad (3)$$

where:

D = measured diameter of the vane, in. [mm],
 H = measured height of the vane, in. [mm],

14.2.1 Thus, for a 0.500 by 0.500 in. [12.7 by 12.7 mm] vane:

$$K = 0.0001515 \text{ ft}^3 \text{ (reciprocal} = 6600 \text{ ft}^{-3}\text{)} \\ = 4.290 \times 10^{-6} \text{ m}^3,$$

and for a 0.5 by 1.0 in. [12.7 by 25.4 mm] vane,

$$K = 0.0002651 \text{ ft}^3 \text{ (reciprocal} = 3772 \text{ ft}^{-3}\text{)} \\ = 7.508 \times 10^{-6} \text{ m}^3.$$

NOTE 12—For purposes of demonstration, values of K , which is an intermediate calculation term, are rounded and approximate. For actual calculations, the user should not round intermediate values.

14.3 Since the undrained shear strength, τ , is required, it is more useful to write the vane equation as follows:

$$\tau = T \times k \quad (4)$$

where:

$k = \frac{1}{K}$, and
 T = measured torque, lbf-ft [N·m].

0.5 by 0.5 in. [12.7 by 12.7 mm] vane

$$k_1 = 6600 \text{ ft}^{-3} [2.34 \times 10^+5 \text{ m}^{-3}]$$

0.5 by 1.0 in. [12.7 by 25.4 mm] vane

$$k_2 = 3772 \text{ ft}^{-3} [1.33 \times 10^+5 \text{ m}^{-3}]$$

14.4 If the vane torque is to be measured utilizing a standard vane shear device by noting the deflection of springs with known constants, a relationship between vane torque and spring deflection may be established through the calibration procedure described in Section 10 as shown in Fig. 5a. Alternatively, a similar calibration curve for an electrical torque transducer may be developed as shown in Fig. 5b.

14.5 The torque, T , also may be expressed in terms of spring deflection in degrees, as follows:

$$T = \frac{(\Delta)}{(B)(12)} \text{ (Inch - Pound Units)} \quad (5)$$

$$T = \frac{\Delta}{B} \text{ [SI Units]} \quad (6)$$

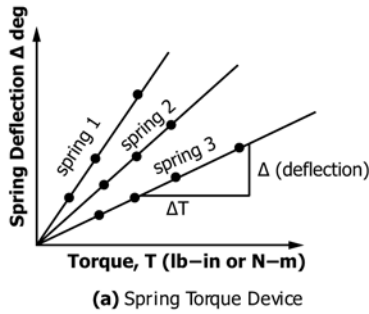

$$B = \text{slope} = \frac{\Delta \text{ deflection}}{\Delta \text{ torque}}$$

Example using a No. 2 Spring

$$B = \frac{151 \text{ deg}}{2.5 \text{ lb-in.}}$$

$$B = 60.4 \frac{\text{deg}}{\text{lb-in}}$$

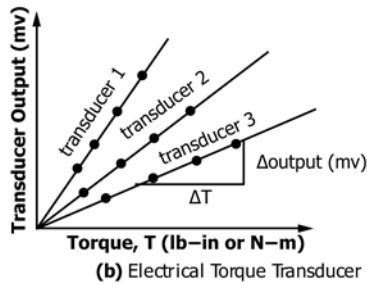

$$B = \text{slope} = \frac{\Delta \text{ output}}{\Delta \text{ torque}}$$

Example Method (1)

$$B = \frac{2.0 \text{ mv}}{5.0 \text{ lb-in}} = 0.40 \frac{\text{mv}}{\text{lb-in}}$$

Method (2)

$$B = \frac{4 \text{ in (chart deflection)}}{5.0 \text{ lb-in}} = 0.8 \frac{\text{inch}}{\text{lb-in}}$$

FIG. 5 Determination of Calibration Factors for Vane Torque Units

where:

T = torque in lbf·ft [N·m],

B = slope of calibration curve in °/lbf-in. (see Fig. 5a) [°/N·m], and

Δ = deflection in degrees.

14.6 The shear strength (τ) may then be obtained from the following equation:

$$\tau = (\Delta)(b)k \quad (7)$$

where:

τ = undrained shear strength, lbf/ft² [N/m²],

Δ = spring deflection, degrees (or transducer output in mV),

b = (1/12B), lbf·ft/° or b = (1/B), [N·m/°], and

k = 1/K, ft⁻³ [m⁻³].

14.7 Establish the spring deflection and torque relationship for each spring or transducer to be used in the vane shear tests as follows:

Spring/ Transducer No.	B	$b = (1/12B)$
Weakest	ex. $\frac{193^\circ}{1.0 \text{ lbf-in.}} = 193.0^\circ/\text{lbf-in.}$	ex. $\frac{1}{12 \text{ in./ft} \times 193^\circ/\text{lbf-in.}} = 0.0004318 \text{ lbf-ft}^\circ$
etc.	etc.	etc.

14.8 Thus, for a 1:1 or 2:1 vane blade, shear strength may be computed by the following:

$$\tau = (\Delta)R \quad (8)$$

where:

τ = shear strength in lbf/ft² [kPa],

Δ = deflection in degrees or transducer output in mV, and

R = (b) k constant.

Vane Size	1:1	2:1
Spring No.	$R = bk_1$	$R = bk_2$
Weakest	2.85 ^A	1.63
etc.	ex. (0.136) ^B	ex. (0.0780)
	etc.	etc.

^A In inch-pound units, yields τ in lbf/ft².

^B In SI units, yields τ in kPa.

15. Report: Test Data Sheet(s)/Form(s)

15.1 The methodology used to specify how data are recorded on the test data sheet(s)/form(s), as described below, is covered in 1.4.

15.2 For each vane test report the following information:

15.2.1 Date of the test, personnel conducting test.

15.2.2 Boring number, sample or tube number, sample depth, vane test depth, soil type in accordance with Practice D2488.

15.2.3 Size and shape of the vane, spring number or torque transducer number, include calibration curve or torque transducer constant, recorder settings.

15.2.4 Maximum torque reading to the nearest three significant digits, and intermediate readings if required for the intact test, include torque transducer stress strain plots.

15.2.5 Maximum torque reading for the remolded test to the nearest three significant digits, and number of revolutions used to remold.

15.2.6 Vane shear strength, to the nearest two significant digits, in lbf/ft² [kPa].



15.2.7 Torque spring or Vane Rotation rate in $^{\circ}/\text{min}$ [rad/min], rate of shear at vane blade edges, time to failure of the test (maximum rotation–rotation rate) where applicable.

15.2.8 Type vane apparatus used (manufacturer, model).

15.2.9 Notes on any deviations from standard procedure.

16. Precision and Bias

16.1 *Precision*—Due to the nature of soil tested by this method, it is too costly at this time to produce multiple specimens which have uniform physical properties. Any varia-

tion observed in the data is just as likely to be due to specimen variation as to operator or laboratory testing variation. Subcommittee D18.05 welcomes proposals that would allow for development of a valid precision statement.

16.2 *Bias*—There is no accepted reference value for this test method; therefore bias cannot be determined.

17. Keywords

17.1 clays; intact; laboratory; miniature; remolded; saturated; shear value; undrained strength

REFERENCES

- (1) Aas, G., “A Study of the Effect of Shape of Vane and Rates of Strain On In-Situ Shear Strength of Clays,” *Proceedings 6th Intl. Conference on Soil Mechanics and Foundation Engineering*, Vol. 2, 1966, pp. 141–145.
- (2) Richardson, A., “In Situ Determination of Anisotropy,” *Proceedings In Situ Measurements*, Vol. I, ASCE, 1974, pp. 336–349.
- (3) Perlow, M. and Richards, A. F., “Influence of Shear Velocity in Vane Shear Strength,” *Journal of the Geotechnical Engineering Division, Proceedings of the American Society of Civil Engineers*, Vol. 103, No. GTI, 1977, pp. 19–32.
- (4) Lee, H. J., “State of the Art: Laboratory Determination of the Strength of Marine Soils,” *Strength Testing of Marine Sediments: Laboratory and In Situ Measurements*, ASTM STP 883, ASTM 1985, pp. 181–250.
- (5) Ladd, C. C., Discussion: “Measurement of In Situ Shear Strength,” *Proceedings In Situ Measurements*, Vol. II, ASCE, 1975, pp. 153–160.
- (6) Larsson, R., “Undrained Shear Strength,” *Canadian Geotechnical Journal*, Vol. 17, No. 4, November 1980, pp. 591–602.

SUMMARY OF CHANGES

In accordance with Committee D18 policy, this section identifies the location of changes to this standard since the last edition (2013) that may impact the use of this standard. (January 1, 2016)

- (1) Added the plural Method(s) to title to be consistent with Methods A and B described in the text.
- (2) Revised 1.5 (added 1.5.1).
- (3) Added reference to Terminology D653 in Section 2 and 3.
- (4) Added references to Test Methods D2216 in Sections 2 and 13 and changed “moisture” references to “water.”
- (5) Replaced term “undisturbed” with “intact” throughout.

ASTM International takes no position respecting the validity of any patent rights asserted in connection with any item mentioned in this standard. Users of this standard are expressly advised that determination of the validity of any such patent rights, and the risk of infringement of such rights, are entirely their own responsibility.

This standard is subject to revision at any time by the responsible technical committee and must be reviewed every five years and if not revised, either reapproved or withdrawn. Your comments are invited either for revision of this standard or for additional standards and should be addressed to ASTM International Headquarters. Your comments will receive careful consideration at a meeting of the responsible technical committee, which you may attend. If you feel that your comments have not received a fair hearing you should make your views known to the ASTM Committee on Standards, at the address shown below.

This standard is copyrighted by ASTM International, 100 Barr Harbor Drive, PO Box C700, West Conshohocken, PA 19428-2959, United States. Individual reprints (single or multiple copies) of this standard may be obtained by contacting ASTM at the above address or at 610-832-9585 (phone), 610-832-9555 (fax), or service@astm.org (e-mail); or through the ASTM website (www.astm.org). Permission rights to photocopy the standard may also be secured from the Copyright Clearance Center, 222 Rosewood Drive, Danvers, MA 01923, Tel: (978) 646-2600; http://www.copyright.com/