



ارائه شده توسط:

سایت ترجمه فا

مرجع جدیدترین مقالات ترجمه شده

از نشریات معتبر

# Nano-Composites for Water Remediation: A Review

Sarah J. Tesh and Thomas B. Scott\*

As global populations continue to increase, the pressure on water supplies will inevitably intensify. Consequently the international need for more efficient and cost effective water remediation technologies will also rise. The introduction of nano-technology into the industry may represent a significant advancement and zero-valent iron nano-particles (INPs) have been thoroughly studied for potential remediation applications. However, the application of water dispersed INP suspensions is limited and somewhat contentious on the grounds of safety, whilst INP reaction mechanisms, transport properties and ecotoxicity are areas still under investigation. Theoretically, the development of nano-composites containing INPs to overcome these issues provides the logical next step for developing nano-materials that are better suited to wide application across the water industry. This review provides an overview of the range of static, bulk nano-composites containing INPs being developed, whilst highlighting the limitations of individual solutions, overall classes of technology, and lack of comparative testing for nano-composites. The review discusses what further developments are needed to optimize nano-composite water remediation systems to subsequently achieve commercial maturity.

## 1. Introduction

Water contamination is a major international problem caused by industrial, domestic and environmental influences. The United Nations estimates that 300–500 million tons of heavy metals, solvents and other waste are released into the world's water supplies each year as a harmful by-product of industrial activity.<sup>[1]</sup> Water contamination can also be naturally derived. For example, arsenic contamination is a serious issue in countries such as Bangladesh, West Bengal (India) and Nepal due to the weathering of rocks that naturally contain arsenic.<sup>[2–6]</sup> Furthermore, as global populations continue to grow the human pressure exerted on our water supplies is expected to intensify with potentially greater likelihood of pollution.

Over the past decade nano-technology has been increasingly investigated as a potential replacement for traditional treatment methods and reactive agents in order to deliver clean water at a reduced cost whilst simultaneously meeting increasingly stringent water quality standards.<sup>[7]</sup> However, the exact definitions of 'nano-scale' and 'nano-material' are still subjects of controversy.

In 2010, the Joint Research Centre (JCR) of the European Commission published a report highlighting the international range of definitions.<sup>[8]</sup> Just within the UK two definitions were found for the term nano-scale; the UK Department for Environment, Food and Rural Affairs (DEFRA) defined it as 200 nm, whilst other organizations used 100 nm. Following recommendations made by the JCR, in October 2011 the European Commission adopted the following definition of 'nano-material' for regulatory purposes:<sup>[9]</sup>

*A natural, incidental or manufactured material containing particles, in an unbound state or as an aggregate or as an agglomerate and where, for 50% or more of the particles in the number size distribution, one or more external dimensions are in the size range 1 nm – 100 nm.*

Due to their minuscule size, nano-materials exhibit different physical, chemical and biological characteristics when compared to their larger, micro- and macro-scale counterparts

(<100 nm).<sup>[8,10–13]</sup> The nano-materials have a larger surface area to volume ratio and consequently a higher density of surface reaction sites per unit mass. Furthermore, surface free-energy is observed to be greater for nano-materials than for micro- or macro-scale counterparts. Nano-materials, therefore, display a higher reactivity for surface mediated processes. However, as the particle size approaches the electron mean-free path and wavelength scales (below approximately 30 nm), quantum size effects become apparent and fundamental physical characteristics are significantly changed again. These effects can counteract the increased reactivity as demonstrated by Sharma et al.,<sup>[14]</sup> with many further comprehensive studies of properties specific to nano-materials readily found in literature.

When within the optimum size range, nano-materials potentially represent a more efficient alternative to current materials used for water treatment.<sup>[7]</sup> A rapidly emerging technology already achieving commercial use in America is nano-particle (NP) injection.<sup>[10,15–18]</sup> The NPs, usually zero valent iron nano-particles (INPs), are injected into the ground as a dry powder or slurry to directly treat contaminated groundwater. The NPs can be either deliberately immobilized, and hence perform as a deep underground permeable reactive barrier (PRB), or mobilized, allowing the NPs to migrate with the contaminated plume of water (Figure 1).

This technique, however, highlights multiple disadvantages of using 'free' NPs for remediation including the important fact that NP behavior is still not fully understood. It is well recognized that the dispersion of NPs through a

S. J. Tesh, Dr. T. B. Scott  
Interface Analysis Centre  
School of Physics  
University of Bristol

H. H. Wills Physics Laboratory  
Tyndall Avenue, Bristol BS8 1TL, United Kingdom  
E-mail: t.b.scott@bristol.ac.uk



DOI: 10.1002/adma.201401376

groundwater system will be limited by multiple processes; mineral sorption, microbiological activity, aggregation and formation of voluminous corrosion products.<sup>[10,13,18–24]</sup> INPs are particularly prone to aggregation and sedimentation because of their strong magnetic properties<sup>[21,25]</sup> in addition to electrostatic NP-NP attractions which operate most effectively in concentrated particle suspensions (i.e. slurries). Multiple studies in the literature have developed methods for avoiding these problems by adapting the NPs themselves, as illustrated in **Figure 2**, to limit or negate inter-particle attractions.

Surfactants<sup>[10,18,26–32]</sup> or polymers<sup>[22,33–62]</sup> can be added to the NP surfaces to encourage steric hindrance and alter the surface charge to prevent electrostatic attraction. The NPs can also be incorporated into other mobile structures such as carbon forms,<sup>[63–78]</sup> silica<sup>[79–87]</sup> and colloidal clays.<sup>[88–93]</sup> However, the exact transport and retardation mechanisms occurring within the ground are unique to each treatment scenario and dictated by multiple factors that can vary over time, including soil composition, flow rates, pH and Eh balance and bacterial communities. These variables are difficult to predict and would require unique tailoring of the NPs for each situation. Changes in the groundwater system (natural or otherwise) may also cause contaminants adsorbed to the surface of NPs to become remobilized and surface adaptations to be reversed or become redundant – consequences that become inevitable when considering the operational difficulty of removing the NPs from the ground. Furthermore, there is relatively little known about the long-term ecotoxicological effects of freely dispersed NPs in the environment<sup>[49,94–101]</sup> – the same properties that provide the remediative qualities could also make them hazardous for living organisms. If, in the future, NPs themselves are proven as an unacceptable toxic risk then contractors that have deployed NPs via injection may subsequently become liable for NP clean-up.

As remediation methods need to have non-toxic reaction agents providing long term and stable removal mechanisms, the disadvantages highlighted make it difficult to establish whether this technology, as it currently exists, can be safely applied. Hence, although there is currently no argument for or against toxicity, the UK is taking a precautionary approach for introducing engineered NPs into the environment. This action follows reports by the Royal Society and Royal Academy of Engineering (2004)<sup>[99]</sup> and CL:AIRE (Contaminated Land: Applications in Real Environments), for the UK Department for Environment, Food and Rural Affairs (2011).<sup>[96]</sup> Both reports highlight the need for more fundamental research into nanotoxicology and NP behavior in subsurface environmental systems.

To avoid the limitations outlined it would be highly advantageous to develop a remediation method that utilizes the reactivity of NPs whilst avoiding the release of free NPs into the environment. One possible route is to develop a 'nano-composite', a product defined as:<sup>[102]</sup>

*A multiphase material where at least one of the constituent phases has one dimension less than 100 nm.*

Recent research has spawned a multitude of different permutations of nano-composite, where generally the NPs are combined with a micro- or macro-scale support material. In



**Sarah Tesh** is a postgraduate researcher with a background in Physics, working within the Interface Analysis Centre, School of Physics, at the University of Bristol. Her PhD research involves the development of nano-composites for water treatment, adapting and combining methods and materials to create a composite that is easy to fabricate

and will have a wide application range.



**Dr. Thomas Scott** is Executive Director of the Bristol-Oxford Nuclear Research Centre and Director of the Interface Analysis Centre, a specialist surface and materials science research centre within the School of Physics at the University of Bristol. He is also a lecturer in Earth Sciences, specialising in research relating to

the transport and clean-up of radioactive materials in the environment.

this arrangement the nano-reactivity is still exhibited and complemented by the properties of the accompanying material.

The current article provides a review of emerging iron and iron oxide containing nano-composites that can be used in static water treatment systems, including permeable reactive barriers, batch reactor systems and point-of-use filters. These systems should avoid the problems associated with uncontrolled NP dispersions by holding them, and sorbed contaminants, securely within a stable structure. Iron and iron oxide NPs<sup>[103]</sup> are of particular interest because bulk iron has been used in treatment methods for many years and, as a miniscule derivative, INPs have been thoroughly studied for remediation purposes (see Crane and Scott (2012),<sup>[10]</sup> Zhang<sup>[104]</sup> and all references therein), although primarily for synthetic laboratory solutions. Most significantly, they have been shown to remediate an impressive range of contaminants,<sup>[105]</sup> from heavy metals via adsorption<sup>[2–6,106–114]</sup> to the degradation of chlorinated solvents via chemical reduction,<sup>[115–121]</sup> and at much greater rates than bulk iron.

Although this type of technology looks promising, this review will also highlight areas for research and development that require further improvement if nano-composites are to be a viable realistic water clean-up technology. One major issue that becomes apparent within this article is that there is little to no consistency in performance testing for nano-composites developed by different groups. This makes it very difficult to compare products and decide which are the most promising for further funding and upscaling.

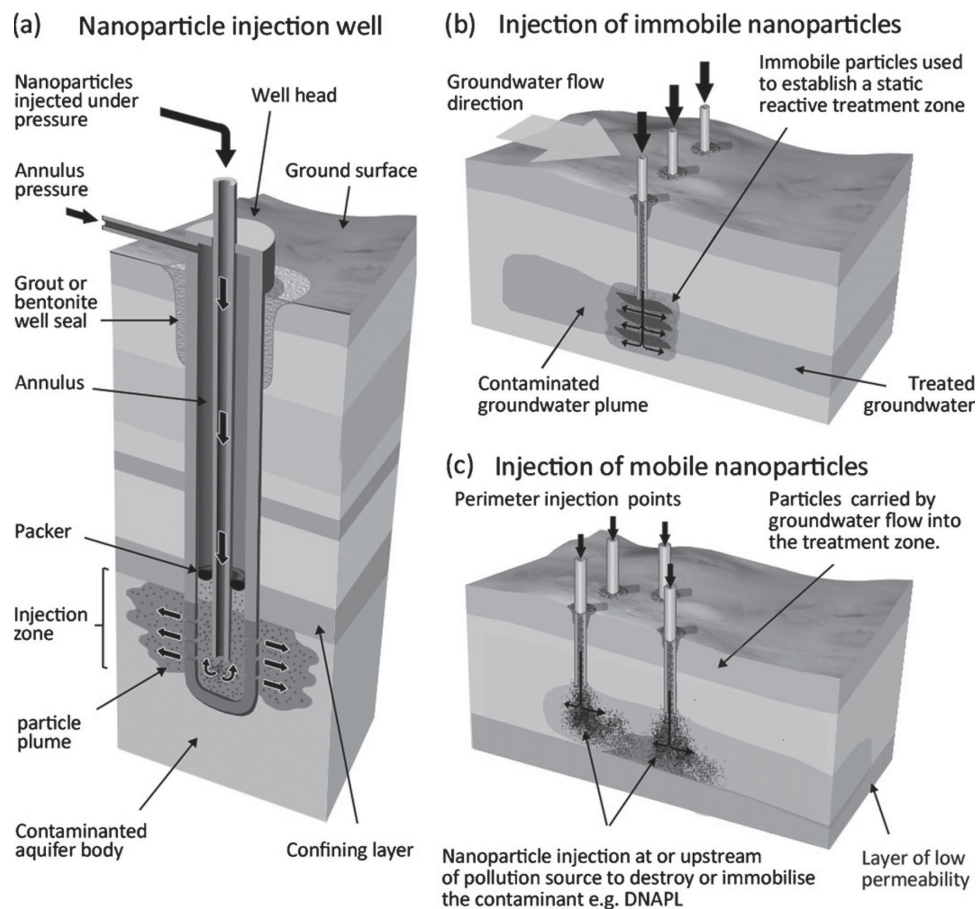

**Figure 1.** A schematic diagram illustrating the aquifer treatment using nano-particle injection processes. Reproduced with permission.<sup>[10]</sup> Copyright 2012, Elsevier.

## 2. Static Nano-composites

Stabilizing NPs with polymers, surfactants and mobile materials has been aimed at improving NP mobility within the subsurface. However, the inherent complexity of natural systems can negate the stabilizing agents which work well in idealized systems and the potential ecotoxicological risks still remain. A more pragmatic solution under investigation is the development of static nano-composites for use in, for example, fixed bed reactors, filter columns, permeable reactive barriers and

domestic filters. These micro- to macro-scale structures avoid the problems of the free NPs described above and represent a potential solution by delivering nano-reactivity within a treatment zone (in an environmental or engineered system) but without uncontrolled release of NPs as they are efficiently anchored onto the parent structure.

There are three general categories of static nano-composite; membranes/mats, beads and three dimensional porous structures (Figure 3). Each of these, and their various benefits

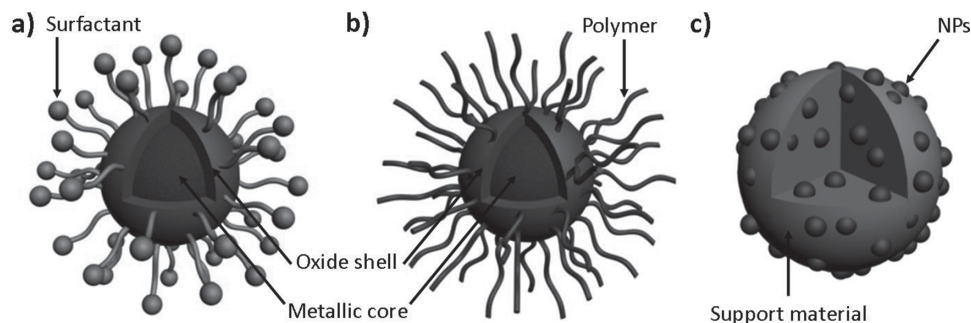

**Figure 2.** A schematic diagram illustrating the three types of mobile nano-materials; (a) Surfactant stabilized NPs, (b) polymer stabilized NPs and (c) NPs supported by another micro-/nano-material.



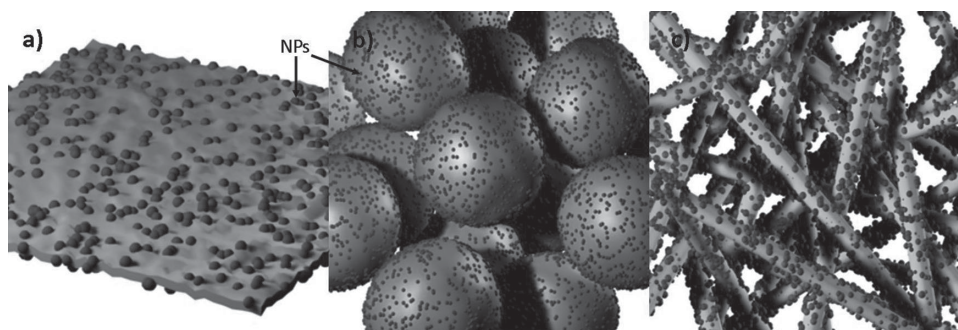

**Figure 3.** A schematic diagram illustrating the three types of static nano-composite.

and drawbacks for deployment and production, will be briefly addressed in the following sections and summarised in **Table 1**.

### 2.1. Membranes and Mats

Membranes traditionally act as size-exclusion based filters, physically preventing harmful microbes or particles from passing through. However, there has been a relatively recent realization that they may be further enhanced by modifying the pores with reactive functional groups and, most recently, NPs. Incorporating NPs into porous micro-filtration membranes is of interest for remediation applications because the membranes offer relatively large pore sizes (50–200 nm) and

**Table 1.** A summary of the three general types of static nano-composites and their advantages and disadvantages.

Type	Advantages	Disadvantages
Membrane	<ul style="list-style-type: none"> <li>· Builds on existing membrane technology for water treatment</li> <li>· Keeps conventional size exclusion properties.</li> </ul>	<ul style="list-style-type: none"> <li>· High water pressures can cause membrane to rupture, releasing NPs and contaminants into water system.</li> <li>· Cannot be recycled or reused</li> </ul>
Beads	<ul style="list-style-type: none"> <li>· Can be easily incorporated into existing infrastructure (e.g. column filters).</li> <li>· Water flux can be tailored by altering bead size and packing density.</li> </ul>	<ul style="list-style-type: none"> <li>· Reactive material within the core of the bead structure does not come into contact with water and contaminants.</li> <li>· Water must flow through channels between beads which generates a high back-flow resistance.</li> <li>· Cannot be cheaply recycled or reused without expensive processing</li> </ul>
Porous 3D structures	<ul style="list-style-type: none"> <li>· Avoids limitations of membranes and beads.</li> <li>· Size and shape can be tailored to existing infrastructure and flow rate requirements</li> <li>· Good capacity for recycling and reusing the substrate material</li> </ul>	<ul style="list-style-type: none"> <li>· Relatively little research has gone into developing such materials.</li> </ul>

open structures.<sup>[122]</sup> These properties are important as they allow the immobilized NPs contained within the membrane to be readily accessible for reaction with the aqueous contaminants. This is especially the case if the flow is turbulent and the contact area is high.

The main bulk structure of the membrane is commonly made from polymers such as poly(vinyl alcohol) (PVA),<sup>[123–125]</sup> poly(acrylic acid) (PAA),<sup>[123,125]</sup> polyethersulfone (PES)<sup>[126]</sup> and chitosan.<sup>[127]</sup> Membrane fabrication methods include phase inversion,<sup>[126]</sup> solution casting<sup>[128]</sup> and thermal grafting polymerization.<sup>[122,129]</sup> However the most popular process is electrospinning,<sup>[123–125,127]</sup> fine fibers are produced by electrostatic repulsion. To incorporate zero-valent INPs, for example, the resulting mat of fibers is then submerged in an aqueous solution of iron salt, where the iron ions complex with the fibers. After rinsing off excess salt, the ions are then chemically reduced, often using sodium borohydride, to form the zero-valent INPs; a relatively cheap and rapid production method.

Using this popular fabrication technique Horzum et al.<sup>[127]</sup> created a chitosan fiber membrane functionalized with INPs and performed one hour batch experiments to demonstrate the material's ability to remediate As(III) and As(V) from synthetic laboratory solutions of varying concentration and pH. The composite was shown to successfully remove both arsenic species but displayed a better affinity to As(III). The percentage of sorption for both ionic forms reduced with increasing concentrations (range investigated was 0.01–25.0 mgL<sup>-1</sup>) and the material's efficiency was also limited by pH, with As(III) and As(V) sorption decreasing once pH raised above 7 and 8 respectively. Although conceptually successful, the percentage of As(V) removal did not raise over 90% and As(III) removal only peaked above 90% under very specific conditions (pH 3.0 and low concentrations), which can not be guaranteed in real world applications, but may be suitable for certain instances of acid mine drainage. It is also wholly possible that the contact area provided by the composite in these experiments was insufficient to achieve complete As removal.

A more successful nano-composite, fabricated using the same technique, has been developed by a group at Donghua University, China. Crosslinked water-stable electrospun PAA/PVA was used as a nano-reactor to complex Fe(III) with the free PAA carboxyl residues for subsequent reductive formation of INPs.<sup>[125,130–132]</sup> The resulting polymer nano-fiber mats were stable, highly porous, reusable and able to rapidly remediate waters spiked with Cu(II) and dye. A following study by Ma

et al.<sup>[123]</sup> took the method further by using the electrospun bers as nano-reactors to prepare core-shell Fe/Pd NPs. By exposing the immobilized INPs on the nano-fibers to Pd(II) solution, bimetallic Fe/Pd NPs were formed via the partial reduction of Pd(II) on the INP surfaces. Batch experiments for the remediation of trichloroethylene (TCE) from synthetic solutions, at relatively low concentrations ( $10 \text{ mgL}^{-1}$ ), were used to compare the performance of the bimetallic NP composite mats with colloidal Fe/Pd NPs and mats containing only INPs or Pd NPs. The mat containing just Pd NPs removed only 6.96% of TCE, with the observed uptake attributed to the polymer mat and not the NPs, confirming that the Pd only acts as a catalyst to the degradation reaction. The remaining three samples degraded over 99% of the TCE and reached an equilibrium within 1.5 hours. The mat containing Fe/Pd exhibited the best performance over a range of TCE concentrations ( $10\text{--}100 \text{ mg}^{-1}$ ), presumably because it combined the benefits of the galvanically active bimetallic NPs and polymer mat. Furthermore, varying ionic strength (NaCl 0–1M) and pH (2.5–6.5) caused no significant change in TCE removal, except to show a slightly enhanced efficiency when more acidic.

An equally impressive example for TCE removal by bimetallic NPs in a polymer membrane, is the work of Parshetti and Doong.<sup>[129]</sup> Using a different fabrication method Parshetti and Doong<sup>[129]</sup> were able to immobilize Fe/Ni bimetallic NPs in polyethylene glycol (PEG) grafted membranes. The study functionalized two polymer membranes, polyvinylidene fluoride (PVDF) and nylon 66, with PEG by trapping ferrous and nickel ions via dip coating and thermal grafting polymerization. The ions were subsequently reduced using  $\text{NaBH}_4$  to create core-shell Fe/Ni NPs uniformly distributed over the membrane surface. The two membranes were then tested and compared for the dechlorination of TCE. The study found nylon 66 to be the most efficient support for TCE degradation because agglomeration was reduced and the nickel content of the bimetallic NPs remained high, both due to the presence of a high number density of multifunctional chelating sites. Almost 100% of TCE was removed within 25 minutes and the composite maintained a high reactivity after 10 days during which 16 cycles of injection occurred.

Although these example studies are conceptually successful within a laboratory with synthetic conditions, there are two key factors yet to be addressed; the flow-through tolerance of the composites and their ability to remediate chemically complex environmental waters. A distinct disadvantage of membrane nano-composites is that they can often only tolerate a slow flow rate (less than  $1 \text{ Lmin}^{-1}$ ) and low water pressure, else the membrane structure is ruptured and/or destroyed. This reduces the likelihood of realistic application in a domestic setting because flow is simply too slow. Additionally, enforcing flow at a higher pressure, i.e., misusing such a filter, increases the likelihood that the NPs will enter the water supply, thereby creating issues downstream. Therefore, it is vital that flow through experiments are performed to test the structural integrity of any new membrane types over a range of flow conditions.

Daraei et al.<sup>[126]</sup> developed a novel nano-composite membrane using the phase inversion method. The PES membrane matrix was enhanced with the addition of polyaniline-magnetite (PANI- $\text{Fe}_3\text{O}_4$ ) NPs, where the PANI formed a 8 nm thick shell

over a 12–28 nm iron oxide core. The resulting membrane was tested for the removal of Cu(II) at pH 5. After comparing different compositions, the optimum membrane was with 0.1 wt% of NPs present, removing 85% of Cu(II) from a solution of  $20 \text{ mgL}^{-1}$  and 75% from a  $5 \text{ mgL}^{-1}$  solution over 2 hrs – eight times more performance than a plain PES membrane. By regenerating the membrane composite with EDTA, it was reusable for 4 cycles, with only 3% loss in Cu(II)adsorption. Unlike the previous examples described above, these contaminant tests were performed in a kinetic system and the pure water flux was examined at 4.5 bars trans-membrane pressure. It was found that the better the Cu(II) retention, the poorer the water flux, with the optimum membrane (0.1 wt% of NPs present) having a water flux of only  $25 \text{ kgm}^{-2} \text{ h}^{-1}$  compared to  $>>25 \text{ kgm}^{-2} \text{ h}^{-1}$  for the pristine PES membrane. It is logical that this occurs; higher flow rates reduce the probability of contaminant removal by reducing the residence time of fluid in the filter. It is also logical that NP-impregnated PES exhibits slower flow-through rates than virgin PES because pore sizes in the membrane are reduced. Although this shows an improved flux rate compared to the previously referenced studies, it is still too low for practical applications. Interestingly, a follow up study was performed to improve the flux to contaminant retention ratio. Daraei et al.<sup>[133]</sup> investigated how acid functionalized and polymer modified multiwalled carbon nano-tubes (CNT) improved the water flux when blended with the PES membranes. It was found that the membrane containing polycitric acid (PCA) offered the most promising results because the PCA formed dendrimers with carboxyl and hydroxyl groups, leading to super-hydrophilicity in the membrane. The membrane maintained a decent flux durability and reusability during three cycles of fouling-washing steps (Figure 4).

This study, combined with NP incorporation, represents the next stage of membrane improvement. However, to be suitable for real world applications, there is still the hurdle of complex environmental water chemistry. In the study by Ma et al.<sup>[123]</sup> mentioned above, tests were performed to investigate NP dissolution over a month – however the tests were performed in pure MilliQ, which is not a realistic representation of a real world water system. Detailed tests analyzing the effect of composite aging (corrosion, dissolution, degradation etc) and clogging in real and complex environmental water samples, and

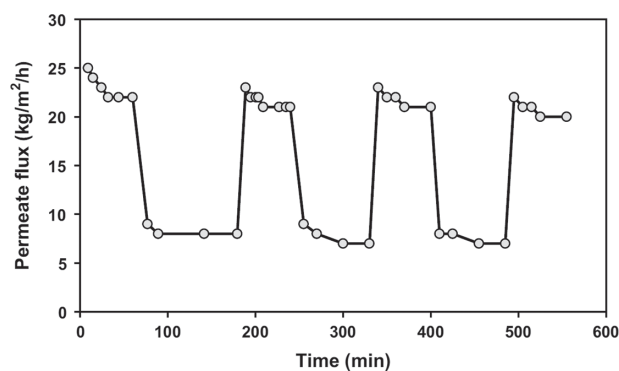

Figure 4. Sequential tests of fouling behavior of PCA-CNT enforced PES membrane. Reproduced with permission.<sup>[133]</sup> Copyright 2013, Elsevier.

including a suspended particle content, are needed to address this limitation.

## 2.2. Beads

Bulk nano-composites can also be in the form of micro-/macro-scale beads or particulates. Beads may be utilized in static treatment systems like filter columns (operated in a manner akin to ion exchange columns) and permeable reactive barriers. The key advantage of these spherical nano-composites is that they can be deployed into existing technology and infrastructure, providing few barriers to operational uptake. Multiple studies by C. Noubactep<sup>[134–142]</sup> have demonstrated the effectiveness of introducing iron into common place sand filter column systems. By doing so the performance is significantly improved and naturally clogs when no reactive iron is left due to the generation of voluminous corrosion products from iron oxidation. By replacing the sand and bulk iron with nano-composite beads, reactivity could be further increased.

Commonly in nano-composite beads the NPs are incorporated into spherical polymer structures and resins, such as chelating resins<sup>[92]</sup> and ion exchange resins.<sup>[143–147]</sup> A popular example in the literature is the biopolymer alginate<sup>[148–156]</sup>

Bezbaruah et al. have published an array of studies investigating the entrapment of INPs within calcium (Ca)-alginate beads.<sup>[149–151]</sup> In each case the composites were fabricated using the same method. Firstly the INPs were synthesized via reduction of an iron salt using sodium borohydride. These were then gently mixed within a solution of sodium-alginate and water, which had been left to stand to ensure no gas bubbles were present. Using a peristaltic pump the mixture was then added drop-wise into a deoxygenated aqueous solution of  $\text{CaCl}_2$ , causing the instant formation of Ca-alginate gel beads containing INPs, which were then dried and hardened. The resulting beads are approximately 5 mm in size (**Figure 5**) and contain NPs with an average size of 35 nm and a range of 10–100 nm.

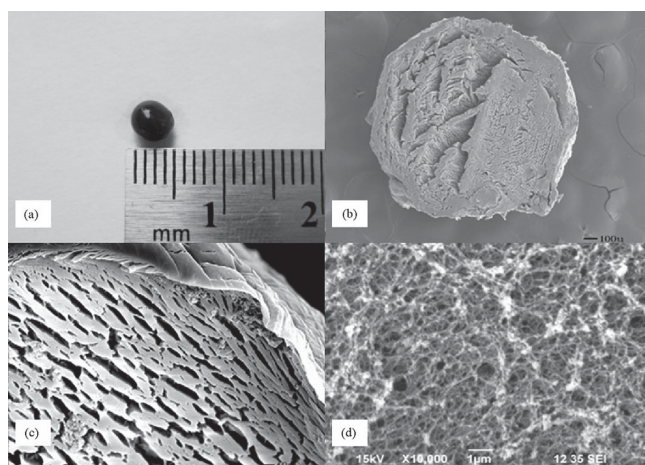
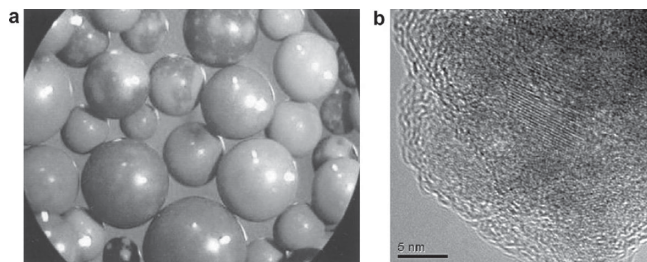

**Figure 5.** (a) A photograph and (b) SEM image of an alginate bead containing INPs. (c) and (d) SEM images of cross sectioned bead. Reproduced with permission.<sup>[149]</sup> Copyright 2009, Elsevier.

Each ensuing study investigated the removal of a different contaminant but under the same physical conditions; i.e., a laboratory made contaminant solution, rotating batch anaerobic reactors, pH not adjusted and samples taken 8 times over 2 hours and in triplicate. To ensure the incorporation of NPs into the beads had not significantly altered their remediative efficiency, the experiments were repeated for free, 'bare' INPs as a comparison. Although the mass of free and entrapped INPs were kept equal within each experiment for consistency, each contaminant required a different amount of the reactive material – presumably based on established literature values. The removal percentages of nitrate (initial concentration range 20 mg-100  $\text{mgL}^{-1}$ ),<sup>[149]</sup> TCE (1–40  $\text{mgL}^{-1}$ )<sup>[150]</sup> and As(V) (1–10  $\text{mgL}^{-1}$ )<sup>[151]</sup> for the nano-composite beads were approximately 50–73%, 89–91% and 85–100% respectively. The performance for free INPs was shown to be very similar to entrapped NPs in each case. This is an excellent example of a series of logical, repetitive tests where only the contaminant involved is varied. Furthermore, the group has begun to study extra factors that would effect the potential commercialization of the material. For example, shelf-life studies are important because they indicate whether the composite could be stock-piled and transported over extended periods of time and retain the same reactivity. In the 2011 study, Bezbaruah et al.<sup>[150]</sup> stored beads synthesized from the same batch in a series of air tight vials containing 2%  $\text{CaCl}_2$  in deoxygenated water, purged with  $\text{N}_2$  gas before sealing and wrapping in aluminium to prevent possible photo reactions. Over the course of six months two vials were tested for TCE removal (initial concentration 30  $\text{mgL}^{-1}$ ) every month. The tests revealed that the reactivity began to fall off, albeit marginally, between month 4 and 5, reducing from approximately 89% removal efficiency to 84%. After six months the efficiency was at 82%. Although the investigations are at a relatively early stage, the work so far is an ideal example of logical nano-composite filter development.

As another material alternative, ion exchange resins are also popular for nano-composite beads.<sup>[143–147]</sup> One example in particular reached commercial availability in 2004<sup>[146]</sup> under the name of ArsenX<sup>np</sup>. Since 1997, Lehigh University (Bethlehem, PA, USA) and Bengal Engineering and Science University (Howrah, India) have been working on units to remove arsenic from water in West Bengal, India. Initially, activated alumina was the adsorbent material employed but to improve performance ArsenX<sup>np</sup> was introduced alongside. The ArsenX<sup>np</sup> beads, diameter 300 to 1200  $\mu\text{m}$ , contain hydrated ferric oxide NPs within a macroporous anion exchange resin (**Figure 6**)<sup>[146,157–161]</sup> designed to have a high selectivity for sorption of oxyanions of arsenic. Alongside the material's remediation properties, the success of the product is also due to its sustainability. The unit (**Figure 7**) is attached to hand-pump driven wells, is gravity fed and requires no electricity or pH adjustment. After more than 20,000 bed volumes, when an arsenic breakthrough of 50  $\text{gL}^{-1}$  occurs, the product is taken to a central regeneration facility and all arsenic waste removed and safely stored. The success of ArsenX<sup>np</sup> demonstrates how new, nano-composite materials are emerging commercially and can be easily deployed within already established infrastructure. However, ArsenX<sup>np</sup> is still a bead nano-composite and therefore suffers from limitations, as outlined below.



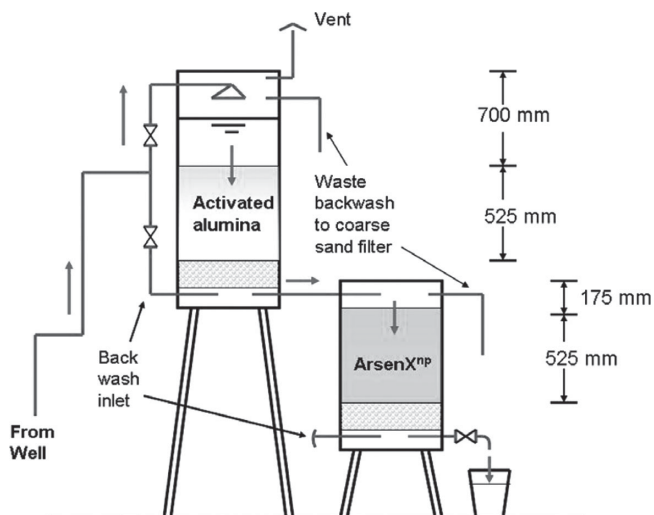

**Figure 6.** (a) A photograph and (b) TEM image of ArsenX<sup>NP</sup> beads. Reproduced with permission.<sup>[146]</sup> Copyright 2007, Elsevier.

Although an advantage of using bead nano-composites in static treatment systems is that the flow rates may be modified by changing the size and packing density of the beads, water must flow through channels between beads which generates a high back-flow resistance. Furthermore, these products tend to contain a significant mass of wasted reactive material within their volume, which is not afforded the opportunity to react with the water because it is physically entrapped within the structure of the bead and never contacts the polluted water. It may also be argued that they are inefficient on the basis that the overall surface area to volume ratio is poor relative to membranes and foams, making treatment systems potentially larger than necessary, which may be an operational limitation.

### 2.3. Porous 3D Structures – The Way Forward?

The third and final solution is the incorporation of NPs into 3D porous, continuous, bulk structures. In theory the continuous structure results in limited unreactive volumes and the large structure can be applied to previously established infrastructure such as column filters and permeable reactive barriers. Furthermore, higher flow rates should also be facilitated as the composite maintains the mechanical properties of the parent support. Despite these logical advantages, however,



**Figure 7.** Schematic detail of construction and operation of a split-column unit used in the field. Reproduced with permission.<sup>[146]</sup> Copyright 2007, Elsevier.

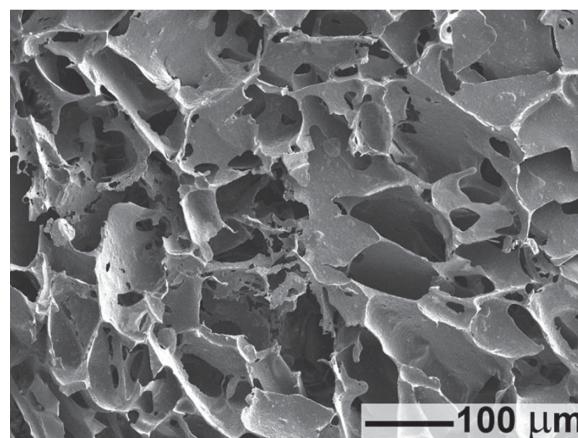

**Figure 8.** SEM of macroporous polymer containing iron oxide NPs. Reproduced with permission.<sup>[163]</sup> Copyright 2011, Elsevier.

there is relatively little literature covering this topic, especially when compared to the vast array of membrane and bead nano-composites. Amongst the few examples available, support materials include polymers,<sup>[162,163]</sup> graphene,<sup>[164]</sup> carbon<sup>[165]</sup> and chitosan.<sup>[166]</sup>

Savina et al.<sup>[163]</sup> developed a macroporous polymer containing iron oxide NPs ( $\alpha$ -Fe<sub>2</sub>O<sub>3</sub> and Fe<sub>3</sub>O<sub>4</sub>), prepared via a simple cryopolymerization process. The NPs were added to a mixture of 2-hydroxyethyl methacrylate and poly(ethylene glycol)diacrylate and dispersed. Immediately after the addition of ammonium persulfate and tetramethylethylenediamine, the mixture was then placed in a freezer (−12 to −18 °C) for 18 hours. The freezing process separates the water from the NPs, monomer, cross-linker and initiator, to create pockets of ice crystals. Once melted, the crystals leaves behind large interconnected pores of up to 100 μm in diameter (Figure 8). The flow rate (measured at constant hydrostatic pressure of approx. 0.1 bar) was  $2.29 \pm 0.34$  and  $2.78 \pm 0.33$  ( $\times 10^{-3}$ ) ms<sup>−1</sup> for the gels containing  $\alpha$ -Fe<sub>2</sub>O<sub>3</sub> and Fe<sub>3</sub>O<sub>4</sub> respectively, when packed in a glass column. This was shown to be very similar to that of gel containing no NPs. This is significantly better than the recommended flow rate for the commercially available ArsenX<sup>NP</sup> beads (described above), which is  $5.0 \times 10^{-5}$  to  $1.1 \times 10^{-4}$  ms<sup>−1</sup> (20–40 bed volumes/h) at conventional pressures up to 8 bar.<sup>[161]</sup> The study continued by investigating the adsorption of As(III). Although the removal efficiency was relatively unaffected through the pH range of 3–9, the performance was significantly reduced when compared to free NPs. The equilibrium adsorption capacity of As(III) for  $\alpha$ -Fe<sub>2</sub>O<sub>3</sub> and Fe<sub>3</sub>O<sub>4</sub> gels was 2.7 and 3.1 mg of As(III) per gram of NPs (or 0.21 and 0.23 As(III)mg/ml of gel) respectively compared to 9.0 and 9.6 mg of As(III) per gram of NPs for free  $\alpha$ -Fe<sub>2</sub>O<sub>3</sub> and Fe<sub>3</sub>O<sub>4</sub> NPs respectively. This significant difference was attributed to the NPs being embedded in the wall of the gel and therefore being less accessible for the contaminant solution (Figure 9). This result suggests that the reactivity would be improved if the NPs were only on the surface of the parent support and not embedded within it.

Another excellent continuous example is by Sankar et al.<sup>[166]</sup> who have recently developed a filter system where NPs are



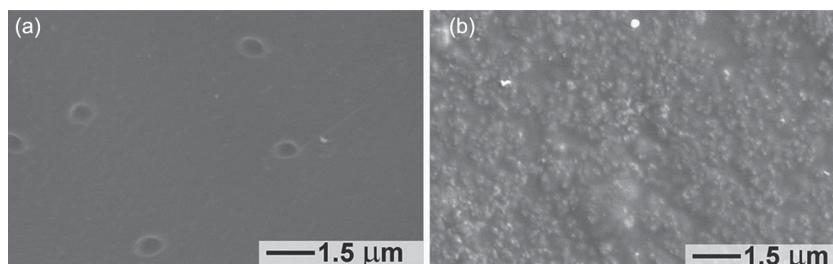
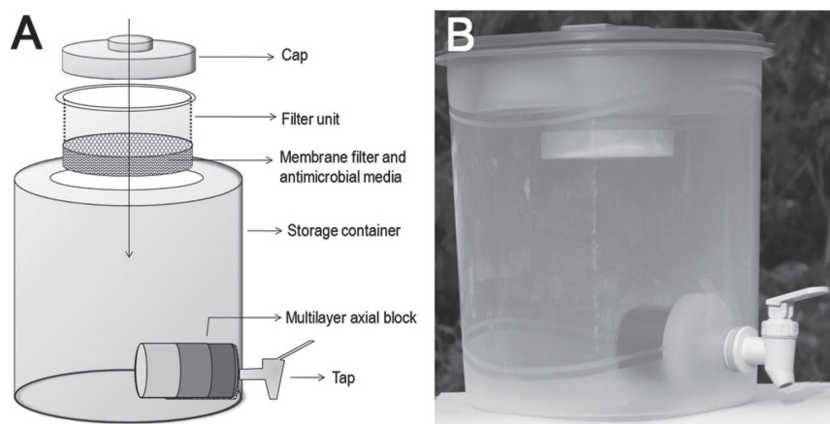

**Figure 9.** SEM of polymer surface when (a) containing no iron oxide NPs and (b) with the NPs embedded within the surface. Reproduced with permission.<sup>[163]</sup> Copyright 2011, Elsevier.

embedded within a nano-crystalline metal oxyhydroxide-chitosan structure. Although primarily focused on silver NPs, the work demonstrates how the composite can be easily tailored to the target contaminant in question by simply altering the composition. For example, silver NPs within a ALOOH-chitosan nano-structure removed bacteria and viruses, whilst composites incorporating magnesium oxide NPs within the ALOOH-chitosan nano-structure targeted heavy metals and an FeOOH-chitosan structure was demonstrated for arsenic removal. Furthermore, Sankar et al.<sup>[166]</sup> developed a point-of-use filter system to incorporate their nano-composite (**Figure 10**) – a great demonstration of how such continuous porous structures can be easily incorporated into simple systems. When containing the anti-bacterial composite, the filter demonstrated outstanding results, cleansing 1,500 L of water with a bacterial load of  $10^5$  CFU/ml before needing to be replaced or reactivated. Assuming consumption of 10 L per day for a family, 120 g of composite was estimated to provide safe drinking water for a year at a cost of only \$2. Whether a similar performance is seen for other nano-material compositions (such as INPs) is yet to be seen.

The added benefit of such a filtration system is that other nano-composites could be placed within the multilayer axial block to set up a treatment train. This is an ideal example of a set up for performance comparison tests between different continuous composite materials.

Unlike membranes and beads, continuous porous nano-composites can be applied to a wider range of remediation



**Figure 10.** The filtration device containing a multilayer axial block within which the tailored composite is placed. Reproduced with permission.<sup>[166]</sup> Copyright 2013, PNAS.

applications. For example, some have been developed to remove oil from water. In order to clean up spills from large volumes of water, ideally a material with superhydrophobicity and superoleophilicity is required. Calcagnile et al.<sup>[162]</sup> developed a white graphene foam that could float, selectively adsorbing oil from the surface of water. The study used commercial polyurethane foams that, when untreated, are hydrophobic and oleophobic. These foams were then functionalized with submicrometre polytetrafluoroethylene (PTFE) particles and superparamagnetic iron oxide NPs via triboelectric charging and deposition respectively. Resultantly the overall synthesis process was simple and the materials inexpensive. It was found that surface morphology and the chemistry of the treated foams affected the adsorption properties and the most efficient foam was created by depositing the NPs before the PTFE. The resulting composite effectively removed the oil and, because of the magnetic properties of the NPs, could then be removed using a magnetic field (**Figure 11**).

Another interesting example is provided by Cong et al.<sup>[164]</sup> where they developed a graphene/iron oxide NP hydrogel. Graphene is an engineered wonder material comprising of  $sp^2$  hybridized carbon atoms and formed with only one atom thickness.<sup>[167]</sup> Although multiple studies have investigated the potential of graphene as an adsorbent itself,<sup>[168–174]</sup> attention has shifted to creating hybrid materials consisting of both graphene and a coupled nano-material. As large scale production of graphene is still challenging,<sup>[167]</sup> most hybrid composites begin with graphene oxide (GO), which is readily available from natural graphite. GO is ideal for iron compounds that have been shown to cross-link with oxygen groups on activated carbon surfaces. This is because on the surface of GO there are multiple oxygen containing groups, e.g., alcohols, ketones and carboxyl groups. In the study by Cong et al.<sup>[164]</sup> GO sheets were reduced by ferrous ions, inducing the self-assembly of a graphene hydrogel containing either  $\alpha$ -FeOOH nano-rods or magnetic  $Fe_3O_4$  NPs, depending on the pH conditions (**Figure 12**).

The resulting structure contained interconnecting networks and displayed significant adsorption of oils and heavy metal ions. The synthesis method was also reported to be versatile and adaptable for the production of other graphene hydrogels containing metal oxide NPs.

Although fascinating examples of hybrid materials, these two examples are once again not directly comparable. Tests using the same oil, amount of oil and same weight of reactive materials are required to declare which is the better composite.

As with membranes and beads, these examples of continuous nano-composites have further demonstrated the need for comparative testing. Furthermore, although theoretically superior to other nano-composite structures, the lack of literature and commercially available products potentially indicates

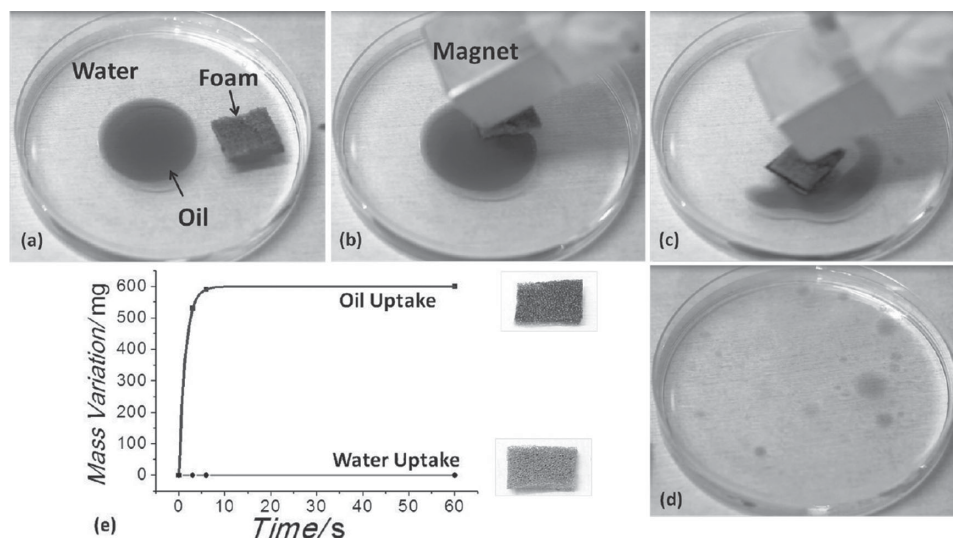

**Figure 11.** A figure demonstrating the oil adsorption efficacy of iron oxide NPs-PTFE functionalized polyurethane foam. Reproduced with permission.<sup>[162]</sup> Copyright 2012, American Chemical Society.

a barrier preventing progress for this category of materials. This could possibly be due to cost but also due to practical limitations that need to be overcome such as avoiding the need for compromise between reactivity, flow rate and structural integrity. This is exemplified in the work of Savina et al.<sup>[163]</sup> who forfeited reactivity for structural integrity.

### 3. What is Holding Back Static Nano-composites?

As can be seen within the literature, a cornucopia of water remediation technologies exist, both as commercially available products and products undergoing research and development. These include adsorbents, flocculants and coagulants, ion exchange resins and size exclusion filters. As the treated water is often used for drinking, there are multiple stringent regulatory requirements that these technologies must fulfill to achieve commercial maturity.

In the US the quality of drinking water is protected under the Safe Drinking Water Act of 1974<sup>[175]</sup> and is regulated by the United States Environmental Protection Agency, the Office of

Ground Water and Drinking Water and yet further organizations at a more local level. Also, NSF International, a third-party organization, often plays an important role by certifying all products that come into contact with drinking water, including water filters, chemical treatments and plumbing.<sup>[176]</sup> In order to gain certification the claims made about a filter's performance must be understood and proved to be true. Furthermore, the NSF Joint Committee on Drinking Water Treatment Units have developed various key standards for evaluation and certification which must be passed depending on the claims made.<sup>[177]</sup>

Meanwhile, within the UK these regulations are outlined and maintained by a combination of authorities – the Drinking Water Inspectorate (the drinking quality regulator for England and Wales) and Drinking Water Quality Regulator for Scotland, the Health Protection Agency (Department of Health), the Department for Regional Development, the Department for Environment, Food and Rural Affairs (DEFRA), as well as local authorities and water suppliers.<sup>[178]</sup> The remediation technologies, alongside materials used for storage or transport of water are judged for suitability on the basis of the demonstrable impact they have on the water by the point of consumption – i.e., are there any residual unwanted chemicals appearing?, is the resulting water suitable for human consumption?, etc. The UK Drinking Water Inspectorate releases an annual report detailing which products have fulfilled these conditions and are approved for use in public water supply.<sup>[179]</sup> This list is purely based on the safety of the drinking water and does not assess the technologies or materials for fitness of purpose.

In all cases the cost of regulatory testing for filter products to be used for drinking water is costly (ranging from \$20 k minimum to \$50k and above) and likely to be prohibitive for individual academics or even universities to take forward. Correspondingly the

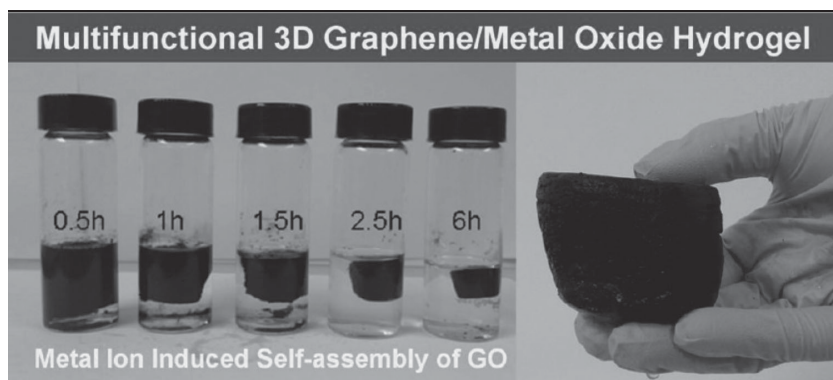

**Figure 12.** A photo displaying the visual self-assembly of a graphene/iron oxide hydrogel. Reproduced with permission.<sup>[164]</sup> Copyright 2012, American Chemical Society.

pathway from promising prototype nano-composite to achieve upscaling and authorization as a market product is likely to be protracted and challenging, requiring one or more rounds of investment.

Nano-composites in particular pose one further problem. Mobile nano-composites are still under scrutiny regarding long term toxicity in the environment and on human health. They are therefore severely limited in commercial applications at the present time. Meanwhile, the more promising bulk nano-composites would need further testing procedures to confirm that no potentially harmful NPs are being released into the drinking water. This may further increase the cost of regulatory testing but is in line with recommendations outlined in the Royal Society report 'Nanoscience and nanotechnologies: Opportunities and Uncertainties'.<sup>[99]</sup>

Furthermore, to be commercially viable, research will need to be pursued to ensure the arising technology is as sustainable as possible. Ideally, to maximise green credentials, the nano-composites should be recyclable, with relatively simple methods available to remove adsorbed contaminants and exhausted NPs and then reuse the substrates. From the resulting NP-contaminant mix desirable metals could then be harvested for further use, therefore providing an economic return, and with the residual waste material would need to be suitably disposed of. Currently, many organisations using NPs follow the traditional chemical safety procedures for 'hazardous materials' throughout the NP life cycle.<sup>[180]</sup> Although this is a good basis for safely handling and disposing of nano-materials, it would be unsurprising if more specific regulations are drawn up in the future to account for new findings that arise regarding their toxicology. In doing so, it is ensured that nano-composites are environmentally friendly throughout their life cycle.

Finally, a key problem, highlighted within this review, with the new materials and methods being researched by academia is that there are no standard testing procedures, no set of standardized test pollutants for laboratory experiments and no size requirements for the overall volume of reactive material. Laboratory tests also often overestimate the performance of the product by testing simplistic water systems.<sup>[10]</sup> This leaves comparison of efficacy very difficult and is currently unsatisfactory for bodies investing in further research and development in this area because it is unclear which product is best.

#### 4. Conclusions and Perspectives

The present review has examined the current state of play for research into nano-composites for water treatment. It is clear that this field of research is swiftly developing, with some 'nano' products already seeing commercial application.

In theory, the ideal composites for industrial or domestic applications are continuous, bulk immobile materials where the nano-reactivity is obtained by anchoring or impregnating a parent material structure with nano-materials, thereby also inheriting the mechanical properties of the parent itself. This type of nano-composite avoids issues surrounding nano-toxicity, an area of potential human and environmental risk still actively under investigation by the international research community.

These composites may be easily introduced into established water treatment infrastructures in the place of traditional reactive agents as a cheaper and more efficient method of reaching ever more stringent legal targets. Possible applications vary from small scale uses, such as domestic point-of-use treatment systems, to environmental in-situ methods akin to permeable reactive barriers, and finally to much larger industrial applications including facilities scale batch or flow through systems. Furthermore this technology lends itself to industrial gas treatment and filtering processes where NP catalysts may be selectively incorporated into the composites to remove either valuable or deleterious species. Reactive nano-composites can be perceived in many wider areas of industry, adding significant weight to the international argument for further development of these materials outside of just water treatment.

Based on the arguments presented here, reactive filter composites that achieve the greatest future commercial success will likely display the following properties;

- Continuous bulk structure so as to avoid the disadvantages of free particles and to ensure the structure is designed such that surface area and reactivity are maximized.
- Strong NP adhesion to ensure that no NPs are released into the water system and wider environment.
- Sound mechanical properties of the parent structure to allow for optimal flow rates.
- High internal surface area to maximize reactivity.
- Ability to remove a large range of contaminants, thereby maximizing potential applications.
- Rechargeable/recyclable for sustainability.
- Recoverable contaminants (metals etc.) allowing waste to be converted to a potentially valuable commodity for economic gain.
- Low production cost to ensure wide spread application is realistic.

To date, no magic bullet nano-composite has yet emerged commercially. The key challenge lies in successfully increasing the surface area of reactive material without sacrificing the mechanical properties to an inoperable level whilst also keeping costs to a minimum. Continued development is still needed to advance such materials, with further investigations into substrates, anchoring/impregnating methods and post-synthesis treatments that may improve the nano-reactivity. Furthermore, standardized tests should be implemented by the academic community to allow for performance comparisons to be made between materials, thereby making it easier for investors to champion specific and promising materials for further development.

Given the present speed of technological development and market uptake, the future looks extremely promising for nano-composites, not only for water treatment, but for many other important global industries.

#### Acknowledgements

We would like to acknowledge our funders at Aldermaston and the University of Bristol in their support for this review. We would also like to thank the numerous authors who kindly agreed to let us reproduce



figures from their excellent journal articles on nano-materials for water treatment.

Received: March 27, 2014

Revised: June 19, 2014

Published online: July 28, 2014

- [1] UNW-DPAC, *UN Report: Water and industry in the green economy: Information brief*, **2011**.
- [2] L. M. Camacho, M. Gutierrez, M. T. Alarcon-Herrera, M. d. L. Villalba, S. Deng, *Chemosphere* **2011**, *83*, 211.
- [3] S. R. Kanel, B. Manning, L. Charlet, H. Choi, *Environ. Sci. Technol.* **2005**, *39*, 1291.
- [4] S. R. Kanel, J.-M. Grenche, H. Choi, *Environ. Sci. Technol.* **2006**, *40*, 2045.
- [5] O. X. Leupin, S. J. Hug, *Water Res.* **2005**, *39*, 1729.
- [6] W. Wan, T. J. Pepping, T. Banerji, S. Chaudhari, D. E. Giammar, *Water Res.* **2011**, *45*, 384.
- [7] T. Masciangioli, W.-X. Zhang, *Environ. Sci. Technol.* **2003**, *37*, 102A.
- [8] G. Lövestam, H. Rauscher, G. Roebben, B. S. Klittgen, N. Gibson, J.-P. Putaud, H. Stamm, *JRC Report: Considerations on a definition of nanomaterial for regulatory purposes*, **2010**.
- [9] European-Commission, Definition of a nanomaterial, [http://ec.europa.eu/environment/chemicals/nanotech/faq/definition\\_en.htm](http://ec.europa.eu/environment/chemicals/nanotech/faq/definition_en.htm), Accessed: January 2014.
- [10] R. A. Crane, T. B. Scott, *J. Hazard. Mater.* **2012**, *211–212*, 112.
- [11] D. L. Huber, *Small* **2005**, *1*, 482.
- [12] J. Jortner, C. N. R. Rao, *Pure Appl. Chem.* **2002**, *74*, 1491.
- [13] J. T. Nurmi, P. G. Tratnyek, V. Sarathy, D. R. Baer, J. E. Amonette, K. Pecher, C. Wang, J. C. Linehan, D. W. Matson, R. L. Penn, M. D. Driessen, *Environ. Sci. & Technol.* **2004**, *39*, 1221.
- [14] R. K. Sharma, P. Sharma, A. Maitra, *J. Colloid Interface Sci.* **2003**, *265*, 134.
- [15] P. Bennett, F. He, D. Zhao, B. Aiken, L. Feldman, *J. Contam. Hydrol.* **2010**, *116*, 35.
- [16] A. Buchau, W. M. Rucker, C. V. d. Boer, N. Klass, *IET Science, Measurement & Technology* **2010**, *4*, 289.
- [17] A. Gavaskar, L. Tatar, W. Condit, *NAVFAC Report: Cost and Performance Report: Nanoscale zero-valent Iron technologies for source remediation* **2005**.
- [18] T. B. Scott, in *Inorganic Nanoparticles: Synthesis, Applications, and Perspectives* (Eds: C. Altavilla, E. Ciliberto), CRC Press, Boca Raton, FL, USA **2011**, Ch. 15.
- [19] M. Elimelech, J. Gregory, X. Jia, R. A. Williams, *Particle deposition and aggregation: Measurement, modelling and simulation* Butterworth-Heinemann, Woburn, MA, USA **1998**.
- [20] C. Noubactep, S. Car, R. Crane, *Water, Air, Soil Pollut.* **2012**, *223*, 1363.
- [21] T. Phenrat, N. Saleh, K. Sirk, R. D. Tilton, G. V. Lowry, *Environ. Sci. Technol.* **2006**, *41*, 284.
- [22] B. Schrick, B. W. Hydutsky, J. L. Blough, T. E. Mallouk, *Chem. Mater.* **2004**, *16*, 2187.
- [23] P. G. Tratnyek, R. L. Johnson, *Nano Today* **2006**, *1*, 44.
- [24] W.-x. Zhang, D. W. Elliott, *Remediation Journal* **2006**, *16*, 7.
- [25] M. Hosokawa, K. Nogi, M. Naito, T. Yokoyama, *Nanoparticle technology handbook: 2<sup>nd</sup> Edition*, Elsevier, Amsterdam, The Netherlands & Oxford, UK **2007**.
- [26] S. Kanel, D. Nepal, B. Manning, H. Choi, *J. Nanopart. Res.* **2007**, *9*, 725.
- [27] Y.-C. Lee, C.-W. Kim, J.-Y. Lee, H.-J. Shin, J.-W. Yang, *Desalin. Water Treat.* **2009**, *10*, 33.
- [28] F. Li, C. Vipulanandan, K. K. Mohanty, *Colloids Surf., A* **2003**, *223*, 103.
- [29] H. Shao, Y. Huang, H. Lee, Y. J. Suh, C. Kim, *J. Appl. Phys.* **2006**, *99*, 08N702.
- [30] Y.-P. Sun, X.-Q. Li, W.-X. Zhang, H. P. Wang, *Colloids Surf., A* **2007**, *308*, 60.
- [31] P. Varanasi, A. Fullana, S. Sidhu, *Chemosphere* **2007**, *66*, 1031.
- [32] P. Zhang, X. Tao, Z. Li, R. S. Bowman, *Environ. Sci. Technol.* **2002**, *36*, 3597.
- [33] J. Biswal, S. P. Ramnani, S. Shirolikar, S. Sabharwal, *J. Appl. Polym. Sci.* **2009**, *114*, 2348.
- [34] S. Comba, R. Sethi, *Water Res.* **2009**, *43*, 3717.
- [35] S. Comba, D. Dalmazzo, E. Santagata, R. Sethi, *J. Hazard. Mater.* **2011**, *185*, 598.
- [36] M. M. Coulter, J. A. Dinglasan, J. B. Goh, S. Nair, D. J. Anderson, V. M. Dong, *Chem. Sci.* **2010**, 772.
- [37] H. Dong, I. M. C. Lo, *Water Res.* **2013**, *47*, 419.
- [38] J. Fresnais, M. Yan, J. Courtois, T. Bostelmann, A. Be, J.-F. Berret, *J. Colloid Interface Sci.* **2013**, *395*, 24.
- [39] F. He, D. Zhao, *Environ. Sci. & Technol.* **2005**, *39*, 3314.
- [40] F. He, D. Zhao, J. Liu, C. B. Roberts, *Ind. Eng. Chem. Res.* **2007**, *46*, 29.
- [41] F. He, D. Zhao, C. Paul, *Water Res.* **2010**, *44*, 2360.
- [42] H. Jans, K. Jans, L. Lagae, G. Borghs, G. Maes, Q. Huo, *Nanotechnology* **2010**, *21*, 455702.
- [43] R. L. Johnson, J. T. Nurmi, G. S. O'Brien Johnson, D. Fan, R. L. O'Brien Johnson, Z. Shi, A. J. Salter-Blanc, P. G. Tratnyek, G. V. Lowry, *Environ. Sci. Technol.* **2013**, *47*, 1573.
- [44] S. R. Kanel, R. R. Goswami, T. P. Clement, M. O. Barnett, D. Zhao, *Environ. Sci. Technol.* **2008**, *42*, 896.
- [45] C. M. Kocur, D. M. O'Carroll, B. E. Sleep, *J. Contam. Hydrol.* **2013**, *145*, 17.
- [46] H. Liu, T. Qian, D. Zhao, *Chin. Sci. Bull.* **2013**, *58*, 275.
- [47] S. Liufu, H. Xiao, Y. Li, *J. Colloid Interface Sci.* **2005**, *281*, 155.
- [48] G. Naja, A. Halasz, S. Thiboutot, G. Ampleman, J. Hawari, *Environ. Sci. Technol.* **2008**, *42*, 4364.
- [49] T. Phenrat, N. Saleh, K. Sirk, H.-J. Kim, G. D. Lowry, G. V. Lowry, *J. Nanopart. Res.* **2008**, *10*, 795.
- [50] P. Raveendran, J. Fu, S. L. Wallen, *J. Amer. Chem. Soc.* **2003**, *125*, 13940.
- [51] A. Tiraferri, K. L. Chen, R. Sethi, M. Elimelech, *J. Colloid Interface Sci.* **2008**, *324*, 71.
- [52] A. Tiraferri, R. Sethi, *J. Nanopart. Res.* **2009**, *11*, 635.
- [53] M. Velimirovic, H. Chen, Q. Simons, L. Bastiaens, *J. Contam. Hydrol.* **2012**, *142–143*, 1.
- [54] E. D. Vecchia, M. Luna, R. Sethi, *Environ. Sci. Technol.* **2009**, *43*, 8942.
- [55] N. Vigneshwaran, R. Nachane, R. Balasubramanya, P. Varadarajan, *Carbohydr. Res.* **2006**, *341*, 2012.
- [56] Z. Wang, B. Tan, I. Hussain, N. Schaeffer, M. F. Wyatt, M. Brust, A. I. Cooper, *Langmuir* **2007**, *23*, 885.
- [57] W. Wang, M. Zhou, *Colloids Surf., A* **2010**, *369*, 232.
- [58] Q. Wang, H. Qian, Y. Yang, Z. Zhang, C. Naman, X. Xu, *J. Contam. Hydrol.* **2010**, *114*, 35.
- [59] Y. Xu, D. Zhao, *Water Res.* **2007**, *41*, 2101.
- [60] D. Xue, R. Sethi, *J. Nanopart. Res.* **2012**, *14*, 1.
- [61] S. Yuan, H. Long, W. Xie, P. Liao, M. Tong, *Geoderma* **2012**, *185/186*, 18.
- [62] M. Zhang, F. He, D. Zhao, X. Hao, *Water Res.* **2011**, *45*, 2401.
- [63] V. Chandra, J. Park, Y. Chun, J. W. Lee, I.-C. Hwang, K. S. Kim, *ACS Nano* **2010**, *4*, 3979.
- [64] C. Chang, F. Lian, L. Zhu, *Environ. Pollut.* **2011**, *159*, 2507.
- [65] H. Choi, S. R. Al-Abed, S. Agarwal, D. D. Dionysiou, *Chem. Mater.* **2008**, *20*, 3649.
- [66] H. Choi, S. R. Al-Abed, *J. Hazard. Mater.* **2010**, *179*, 869.

- [67] L. B. Hoch, E. J. Mack, B. W. Hydutsky, J. M. Hershman, J. M. Skluzacek, T. E. Mallouk, *Environ. Sci. Technol.* **2008**, *42*, 2600.
- [68] Z. Liu, F.-S. Zhang, *Bioresour. Technol.* **2010**, *101*, 2562.
- [69] K. Mackenzie, S. Bleyl, A. Georgi, F.-D. Kopinke, *Water Res.* **2012**, *46*, 3817.
- [70] S. Nethaji, A. Sivasamy, A. Mandal, *Bioresour. Technol.* **2013**, *134*, 94.
- [71] A. Sharma, N. Verma, A. Sharma, D. Deva, N. Sankaramakrishnan, *Chem. Eng. Sci.* **2010**, *65*, 3591.
- [72] T. Sreepasad, S. M. Maliyekkal, K. Lisha, T. Pradeep, *J. Hazard. Mater.* **2011**, *186*, 921.
- [73] H.-H. Tseng, J.-G. Su, C. Liang, *J. Hazard. Mater.* **2011**, *192*, 500.
- [74] J. Xu, N. Gao, Y. Tang, Y. Deng, M. Sui, *J. Environ. Sci.* **2010**, *22*, 1807.
- [75] Q. Yan, C. Wan, J. Liu, J. Gao, F. Yu, J. Zhang, Z. Cai, *Green Chem.* **2013**, *15*, 1631.
- [76] J. Zhan, I. Kolesnichenko, B. Sunkara, J. He, G. L. McPherson, G. Piringer, V. T. John, *Environ. Sci. Technol.* **2011**, *45*, 1949.
- [77] D. Zhang, S. Q. Shi, J. Pittman, Charles, U. D. Jiang, W. Che, Z. Gai, J. Y. Howe, K. L. More, A. Antonyraj, *J. Nanopart. Res.* **2012**, *14*, 1.
- [78] M. Zhang, B. Gao, S. Varnoosfaderani, A. Hebard, Y. Yao, M. Inyang, *Bioresour. Technol.* **2013**, *130*, 457.
- [79] D. He, X. He, K. Wang, Y. Zhao, Z. Zou, *Langmuir* **2013**, *29*, 5896.
- [80] M. Kalantari, M. Kazemeini, A. Arpanaei, *Mater. Res. Bull.* **2013**, *48*, 2023.
- [81] Y. Li, T. Li, Z. Jin, *J. Environ. Sci.* **2011**, *23*, 1211.
- [82] Y. Li, Z. Jin, T. Li, Z. Xiu, *Sci. Total Environ.* **2012**, *421–422*, 260.
- [83] K. Mandel, F. Hutter, C. Gellermann, G. Sextl, *Sep. Puri. Technol.* **2013**, *109*, 144.
- [84] M. Padervand, M. Gholami, *Environ. Sci. Pollut. Res.* **2013**, *20*, 3900.
- [85] X. Qiu, Z. Fang, B. Liang, F. Gu, Z. Xu, *J. Hazard. Mater.* **2011**, *193*, 70.
- [86] N. Zaitseva, V. Zaitsev, A. Walcarius, *J. Hazard. Mater.* **2013**, *250–251*, 454.
- [87] J. Zhan, T. Zheng, G. Piringer, C. Day, G. L. McPherson, Y. Lu, K. Papadopoulos, V. T. John, *Environ. Sci. Technol.* **2008**, *42*, 8871.
- [88] R. L. Frost, Y. Xi, H. He, *J. Colloid Interface Sci.* **2010**, *341*, 153.
- [89] H. Jia, C. Wang, *Chem. Eng. J.* **2012**, *191*, 202.
- [90] S. Luo, P. Qin, J. Shao, L. Peng, Q. Zeng, J.-D. Gu, *Chem. Eng. J.* **2013**, *223*, 1.
- [91] N. Rajic, D. Stojakovic, N. Daneu, A. Recnik, *J. Phys. Chem. Solids* **2011**, *72*, 800.
- [92] L.-n. Shi, X. Zhang, Z.-l. Chen, *Water Res.* **2011**, *45*, 886.
- [93] X. Zhang, S. Lin, X.-Q. Lu, Z. liang Chen, *Chem. Eng. J.* **2010**, *163*, 243.
- [94] P. V. AshaRani, G. Low Kah Mun, M. P. Hande, S. Valiyaveettil, *ACS Nano* **2008**, *3*, 279.
- [95] M. Au-an, W. Achouak, J. Rose, M.-A. Roncato, C. Chaneac, D. T. Waite, A. Masion, J. C. Woicik, M. R. Wiesner, J.-Y. Bottero, *Environ. Sci. Technol.* **2008**, *42*, 6730.
- [96] P. Bardos, B. Bone, D. Elliott, N. Hartog, J. Henstock, P. Nathanail, *Contaminated Land: Applications in Real Environments* **2011**, Technical report.
- [97] S. M. Cook, *US EPA – OSWER & OSRTI Report: Assessing the use and application of zero-valent iron nanoparticle technology for remediation at contaminated sites*, **2009**.
- [98] M. Diao, M. Yao, *Water Res.* **2009**, *43*, 5243.
- [99] A. Dowling, R. Clift, N. Grobert, D. Hutton, R. Oliver, O. O'Neill, J. Pethica, N. Pidgeon, J. Porritt, J. Ryan, A. Seaton, S. Tendler, M. Welland, R. Whatmore, *The Royal Society & The Royal Academy of Engineering Report: Nanoscience and nanotechnologies: Opportunities and uncertainties*, **2004**.
- [100] C. R. Keenan, R. Goth-Goldstein, D. Lucas, D. L. Sedlak, *Environ. Sci. Technol.* **2009**, *43*, 4555.
- [101] T. R. Pisanic II, J. D. Blackwell, V. I. Shubayev, R. R. Fiones, S. Jin, *Biomaterials* **2007**, *28*, 2572.
- [102] P. M. Ajayan, L. S. Schadler, P. V. Braun, *Nanocomposite Science and Technology*, Wiley-VCH, Weinheim, Germany **2003**.
- [103] G. N. Glavee, K. J. Klabunde, C. M. Sorensen, G. C. Hadjipanayis, *Inorg. Chem.* **1995**, *34*, 28.
- [104] W.-x. Zhang, *J. Nanopart. Res.* **2003**, *5*, 323.
- [105] R. Miehr, P. G. Tratnyek, J. Z. Bandstra, M. M. Scherer, M. J. Alowitz, E. J. Bylaska, *Environ. Sci. Technol.* **2003**, *38*, 139.
- [106] R. A. Crane, M. Dickinson, I. C. Popescu, T. B. Scott, *Water Res.* **2011**, *45*, 2931.
- [107] M. Dickinson, T. B. Scott, *J. Hazard. Mater.* **2010**, *178*, 171.
- [108] D. Karabelli, C. Üzüüm, T. Shahwan, A. E. Eroglu, T. B. Scott, K. R. Hallam, I. Lieberwirth, *Ind. Eng. Chem. Res.* **2008**, *47*, 4758.
- [109] X.-q. Li, W.-x. Zhang, *Langmuir* **2006**, *22*, 4638.
- [110] X.-q. Li, W.-x. Zhang, *J. Phys. Chem., C* **2007**, *111*, 6939.
- [111] J. W. MacFarlane, H. F. Jenkinson, T. B. Scott, *Appl. Catal., B* **2011**, *106*, 181.
- [112] O. Riba, T. B. Scott, K. Vala Ragnarsdottir, G. C. Allen, *Geochim. Cosmochim. Acta* **2008**, *72*, 4047.
- [113] M. Rivero-Huguet, W. D. Marshall, *J. Hazard. Mater.* **2009**, *169*, 1081.
- [114] C. zm, T. Shahwan, A. Eroglu, I. Lieberwirth, T. Scott, K. Hallam, *Chem. Eng. J.* **2008**, *144*, 213.
- [115] R. J. Barnes, O. Riba, M. N. Gardner, A. C. Singer, S. A. Jackman, I. P. Thompson, *Chemosphere* **2010**, *80*, 554.
- [116] R. J. Barnes, O. Riba, M. N. Gardner, T. B. Scott, S. A. Jackman, I. P. Thompson, *Chemosphere* **2010**, *79*, 448.
- [117] S. Choe, S.-H. Lee, Y.-Y. Chang, K.-Y. Hwang, J. Khim, *Chemosphere* **2001**, *42*, 367.
- [118] H. Lien, W. Zhang, *J. Environ. Eng.* **1999**, *125*, 1042.
- [119] Y. Liu, S. A. Majetich, R. D. Tilton, D. S. Sholl, G. V. Lowry, *Environ. Sci. Technol.* **2005**, *39*, 1338.
- [120] T. Satapanajaru, P. Anurakpongatorn, P. Pengthamkeerati, H. Boparai, *Water, Air, Soil Pollut.* **2008**, *192*, 349.
- [121] C. B. Wang, W. X. Zhang, *Environ. Sci. Technol.* **1997**, *31*, 2154.
- [122] J. Xu, D. Bhattacharyya, *J. Phys. Chem., C* **2008**, *112*, 9133.
- [123] H. Ma, Y. Huang, M. Shen, R. Guo, X. Cao, X. Shi, *J. Hazard. Mater.* **2012**, *211–212*, 349.
- [124] N. Mahanta, S. Valiyaveettil, *RSC Adv.* **2013**, *3*, 2776.
- [125] S. Xiao, S. Wu, M. Shen, R. Guo, Q. Huang, S. Wang, X. Shi, *ACS Appl. Mater. Interfaces* **2009**, *1*, 2848.
- [126] P. Daraei, S. S. Madaeni, N. Ghaemi, E. Salehi, M. A. Khadivi, R. Moradian, B. Astinchap, *J. Membr. Sci.* **2012**, *415–416*, 250.
- [127] N. Horzum, M. M. Demir, M. Nairat, T. Shahwan, *RSC Adv.* **2013**, *3*, 7828.
- [128] A. Zendehtnam, M. Arabzadegan, S. Hosseini, N. Robotmili, S. Madaeni, *Korean J. Chem. Eng.* **2013**, *30*, 1265.
- [129] G. K. Parshetti, R.-a. Doong, *Water Res.* **2009**, *43*, 3086.
- [130] S. Xiao, M. Shen, R. Guo, S. Wang, X. Shi, *J. Phys. Chem., C* **2009**, *113*, 18062.
- [131] S. Xiao, M. Shen, R. Guo, Q. Huang, S. Wang, X. Shi, *J. Mater. Chem.* **2010**, *20*, 5700.
- [132] S. Xiao, H. Ma, M. Shen, S. Wang, Q. Huang, X. Shi, *Colloids Surf., A* **2011**, *381*, 48.
- [133] P. Daraei, S. S. Madaeni, N. Ghaemi, M. A. Khadivi, B. Astinchap, R. Moradian, *J. Membr. Sci.* **2013**, *444*, 184.
- [134] S. Bilardi, P. S. Calabr, S. Car, N. Moraci, C. Noubactep, *J. Environ. Manage.* **2013**, *121*, 133.
- [135] K. Miyajima, C. Noubactep, *Chem. Eng. J.* **2012**, *200–202*, 433.
- [136] K. Miyajima, C. Noubactep, *Chem. Eng. J.* **2013**, *217*, 310.
- [137] C. Noubactep, A. Schnier, P. Woaf, *CLEAN* **2009**, *37*, 930.

- [138] C. Noubactep, S. Car, *Chem. Eng. J.* **2010**, *162*, 635.
- [139] C. Noubactep, *Chem. Eng. J.* **2010**, *165*, 740.
- [140] C. Noubactep, S. Carr, F. Togue-Kamga, A. Schner, P. Wofo, *CLEAN* **2010**, *38*, 951.
- [141] C. Noubactep, S. Car, B. D. Btatkeu, K. C. P. Nansu-Njiki, *CLEAN* **2012**, *40*, 100.
- [142] C. Noubactep, E. Temgoua, M. A. Rahman, *CLEAN* **2012**, *40*, 798.
- [143] M. J. DeMarco, A. K. SenGupta, J. E. Greenleaf, *Water Res.* **2003**, *37*, 164.
- [144] A. Li, C. Tai, Z. Zhao, Y. Wang, Q. Zhang, G. Jiang, J. Hu, *Environ. Sci. Technol.* **2007**, *41*, 6841.
- [145] B. Pan, H. Qiu, B. Pan, G. Nie, L. Xiao, L. Lv, W. Zhang, Q. Zhang, S. Zheng, *Water Res.* **2010**, *44*, 815.
- [146] S. Sarkar, L. M. Blaney, A. Gupta, D. Ghosh, A. K. SenGupta, *React. Func. Polym.* **2007**, *67*, 1599.
- [147] L. Yang, L. Lv, S. Zhang, B. Pan, W. Zhang, *Chem. Eng. J.* **2011**, *178*, 161.
- [148] P. Agrawal, A. Bajpai, *Toxicol. Environ. Chem.* **2011**, *93*, 1277.
- [149] A. N. Bezbaruah, S. Krajangpan, B. J. Chisholm, E. Khan, J. J. E. Bermudez, *J. Hazard. Mater.* **2009**, *166*, 1339.
- [150] A. Bezbaruah, S. Shanbhogue, S. Simsek, E. Khan, *J. Nanopart. Res.* **2011**, *13*, 6673.
- [151] A. Bezbaruah, H. Kalita, T. Almeelbi, C. Capecci, D. Jacob, A. Ugrinov, S. Payne, *J. Nanopart. Res.* **2013**, *16*, 1.
- [152] H. Kim, H.-J. Hong, J. Jung, S.-H. Kim, J.-W. Yang, *J. Hazard. Mater.* **2010**, *176*, 1038.
- [153] I. Lee, C.-G. Lee, J.-A. Park, J.-K. Kang, S.-Y. Yoon, S.-B. Kim, *Desal. Water Treat.* **2013**, *51*, 3438.
- [154] G. Li, Y. Du, Y. Tao, H. Deng, X. Luo, J. Yang, *Carbohydr. Polym.* **2010**, *82*, 706.
- [155] A. Tiwari, A. Soni, A. K. Bajpai, *Synth. React. Inorg. Met.-Org. Nano-Met. Chem.* **2012**, *42*, 1158.
- [156] D. Wu, L. Zhang, L. Wang, B. Zhu, L. Fan, *J. Chem. Technol. Biotechnol.* **2011**, *86*, 345.
- [157] T. Mller, P. Sylvester, *Water Res.* **2008**, *42*, 1760.
- [158] L. M. Blaney, S. Cinar, A. K. SenGupta, *Water Res.* **2007**, *41*, 1603.
- [159] L. Cumbal, A. K. SenGupta, *Environ. Sci. Technol.* **2005**, *39*, 6508.
- [160] A. K. SenGupta, L. H. Cumbal, *US 7291578 B2*, **2007**.
- [161] P. Sylvester, P. Westerhoff, T. Mller, M. Badruzzaman, O. Boyd, *Environ. Eng. Sci.* **2007**, *24*, 104.
- [162] P. Calcagnile, D. Fragouli, I. S. Bayer, G. C. Anyfantis, L. Martiradonna, P. D. Cozzoli, R. Cingolani, A. Athanassiou, *ACS Nano* **2012**, *6*, 5413.
- [163] I. N. Savina, C. J. English, R. L. Whitby, Y. Zheng, A. Leistner, S. V. Mikhailovsky, A. B. Cundy, *J. Hazard. Mater.* **2011**, *192*, 1002.
- [164] H.-P. Cong, X.-C. Ren, P. Wang, S.-H. Yu, *ACS Nano* **2012**, *6*, 2693.
- [165] J. W. Macfarlane, S. J. Tesh, R. A. Crane, K. R. Hallam, T. B. Scott, *Mater. Sci. Eng. B* **2014**, *182*, 59.
- [166] M. U. Sankar, S. Aigal, S. M. Maliyekkal, A. Chaudhary, Anshup, A. A. Kumar, K. Chaudhari, T. Pradeep, *PNAS* **2013**, *110*, 8459.
- [167] K. Zhang, V. Dwivedi, C. Chi, J. Wu, *J. Hazard. Mater.* **2010**, *182*, 162.
- [168] K. Hu, M. K. Gupta, D. D. Kulkarni, V. V. Tsukruk, *Adv. Mater.* **2013**, *25*, 2301.
- [169] L. Ji, W. Chen, Z. Xu, S. Zheng, D. Zhu, *J. Environ. Qual.* **2013**, *42*, 191.
- [170] X. Li, G. Chen, *Mater. Lett.* **2009**, *63*, 930.
- [171] Y. Li, Q. Du, T. Liu, X. Peng, J. Wang, J. Sun, Y. Wang, S. Wu, Z. Wang, Y. Xia, L. Xia, *Chem. Eng. Res. Des.* **2013**, *91*, 361.
- [172] Q. Liu, J. Shi, L. Zeng, T. Wang, Y. Cai, G. Jiang, *J. Chromatogr., A* **2011**, *1218*, 197.
- [173] M. Machida, T. Mochimaru, H. Tatsumoto, *Carbon* **2006**, *44*, 2681.
- [174] J. Zhao, W. Ren, H.-M. Cheng, *J. Mater. Chem.* **2012**, *22*, 20197.
- [175] U.S.E.P.A., Safe water drinking act, <http://water.epa.gov/lawsregs/rulesregs/sdwa/index.cfm>, Accessed: July 2013.
- [176] NSF-International, About NSF, [http://nsf.org/business/about\\_NSF/](http://nsf.org/business/about_NSF/), Accessed: July 2013.
- [177] NSF-International, Drinking water treatment units, [http://nsf.org/business/drinking\\_water\\_treatment/index.asp?program=DrinkingWatTre](http://nsf.org/business/drinking_water_treatment/index.asp?program=DrinkingWatTre), Accessed: July 2013.
- [178] Drinking Water Inspectorate, *Report: Drinking Water Safety: Guidance to health and water professionals*, **2009**.
- [179] Drinking Water Inspectorate, *Report: List of approved products for use in public water supply in the United Kingdom*, **2013**.
- [180] G. H. Amoabediny, A. Naderi, J. Malakootikhah, M. K. Koohi, S. A. Mortazavi, M. Naderi, H. Rashedi, *J. Phys.:Conf. Ser.* **2009**, *179*, 012037.



این مقاله، از سری مقالات ترجمه شده رایگان سایت ترجمه فا میباشد که با فرمت PDF در اختیار شما عزیزان قرار گرفته است. در صورت تمایل میتوانید با کلیک بر روی دکمه های زیر از سایر مقالات نیز استفاده نمایید:

لیست مقالات ترجمه شده ✓

لیست مقالات ترجمه شده رایگان ✓

لیست جدیدترین مقالات انگلیسی ISI ✓

سایت ترجمه فا ؛ مرجع جدیدترین مقالات ترجمه شده از نشریات معتبر خارجی